

# COMDIAL

Executech™

## MODEL 616 AND 616B ELECTRONIC KEY SYSTEM

- INSTALLATION
  - PROGRAMMING
  - MAINTENANCE

---

Committed to U.S. leadership in business communications

---

IMI 66-037  
JULY, 1986

IMI 66-037  
June, 1986

**INSTALLATION AND MAINTENANCE INFORMATION  
FOR THE Model 616 and 616B  
ELECTRONIC KEY SYSTEMS**

SERIAL NUMBER \_\_\_\_\_

## CHAPTER 1 INTRODUCTION

### SECTION 1 GENERAL INFORMATION

#### MANUAL SCOPE

This publication contains installation and maintenance information for the Model 616B and 616 electronic key systems and associated electronic key telephone sets.

The installation procedures detailed in this manual, for the most part, should be performed by a trained technician. The following service items may, however, be performed by any user at his or her discretion. All other servicing must be performed by factory authorized personnel.

- Place or replace any designation strips on the face of the telephone.
- Replace the telephone line or handset coiled cord.
- Replace telephones and handsets. The handset is a special Comdial type. Other handset types will not work properly.
- Relocate the telephone when it is plugged into the proper system jacks.

#### RELATED INFORMATION

- IMI 01-001 Compliance Requirements To FCC Rules and Regulations Part 68 and 15
- IMI 01-005 Handling Of Electrostatically Sensitive Components
- GCA 70-011 User's Guide

#### GENERAL DESCRIPTION

##### Configuration

The Model 616B and 616 electronic key systems consist of an electronic Key Service Unit (KSU), dedicated electronic key system telephone sets (stations), and interconnecting wiring consisting of small, 4-wire, twisted-pair cable.

This electronic key system is designed to not only provide the economy and features of a conventional "1A2 type" system but also a much easier installation made possible with small size wiring. Advanced operating features are made possible by the electronic technology used in the KSU and the dedicated key system telephone set. The system is equipped for a maximum of 6 lines and 16 stations.

### Model Variations

The Model 616 key system unit has been produced in two versions. The currently produced version is designated as 616B KSU. It is an enhanced unit which provides standard key system features, adds station pin upward compatibility for growth, and includes advanced operating features such as expanded toll restriction and class of service printout data. The earlier produced version is designated as 616 KSU and is currently available only as a service replacement. Specifically, the 616B provides the following operation enhancements: serial data printer port for class of service printout; all-call and zone paging through all system stations; three intercom links; and programmable toll restriction tables.

### KSU Description

The KSU is a fully electronic key service unit. It is essentially a special purpose computer system acting as a communications controller between TELCO or PABX supplied lines and proprietary 3-line and 8-line telephone stations.

The KSU is contained in a functional, modern-style metal housing of contemporary design in keeping with the needs of the modern office environment. It is engineered to be wall or rack mounted.

### Telephone Set Description

The telephone set is an electronic, microprocessor-controlled device. It is designed to allow not only multiline pickup but also single button access to features available from the serving TELCO or PABX switch. All stations are equipped with standard modular jacks.

The telephone sets are available in 3-line (5-button) and 8-line (10-button) handsfree dialing models; 3-line and 8-line full speakerphone models; and an 8-line, handsfree model with a busy lamp field.

### KEY SYSTEM FEATURES

The electronic key telephone system provides a broad range of features. Some of the features are a permanent part of the system while others are programmable as part of the system or station programming procedure. The following paragraphs describe the features.

#### Access Denied (Private Lines)

Access to particular lines can be denied to certain stations in the system through system programming. This access denied feature is programmable on a per line/per station basis.

Add-On Conference (Internal)

This system feature allows the stations, while operating in a private mode, to add another station to an existing call or to a multiline call.

All-Call And Zone Paging - Via Station Speakers (Model 616B KSU)

All-call and zone paging allows the system stations to be used to receive or originate one-way messages in order to find, notify, or summon someone. A station can be enabled by programming to receive all-call and zone paging messages through the station speaker, and to originate them using the station handset. A station can be programmed to only receive messages or programmed to originate messages as well. The programming can enable zone paging in up to four different zones or system-wide, all-call paging. Each station can be programmed to be in any or all zones for both receiving and originating messages. The system defaults to system-wide, all-call paging in zone D with all stations having both receive and originate capability.

Area Paging Interface (Via Spare Station Port)

A station port can be programmed to interface with an external paging amplifier. It can be dial accessed from the other stations in the system. A line port can also be programmed to interface with an external paging amplifier. This paging amplifier can be accessed from the stations in the system with the line select key. DTMF tones can be dialed through the line paging port to provide zone selection if dialed zone selection is available at the external paging amplifier.

Automatic Abandoned Hold Release

If an on-hold party hangs up at the TELCO/PBX end of the communications link, causing an interruption in the tip/ring line current, the system will drop the line off of the hold condition and return it for service. The line select indicator will turn off to indicate an idle line condition. This feature is contingent upon the availability of a loop disconnect feature in the TELCO/PBX equipment.

Automatic Hold Transfer To Intercom (Answer Hold)

If the intercom line is selected while an outside line call is active, this system feature will cause the outside call to be automatically placed on hold.

### Automatic Privacy (Programmable)

A system feature provides automatic privacy on all lines at every station. Automatic privacy prevents other stations from joining a station on an active line unless that station user allows it. Through programming, the system can be configured so that certain lines are normally non-private. When the non-private line is in use at a particular station, users of other stations in the system can join that station user on the non-private line. This can be accomplished by pressing that line select key on their station.

### Automatic Redial (Of Busy Numbers)

An automatic redial of the last dialed number is available at every station. A busy number or unanswered call is automatically redialed by this feature. Once automatic redial is selected, the station will select a line, automatically dial a number, and wait for a response. It will do this once a minute for approximately 10 minutes.

The user must lift the handset to complete the call voice link. Lifting the handset or pressing any other key will cancel further automatic redial action. Users of the optional speakerphone station can complete the call voice link by pressing the MONITOR OFF key instead of lifting the handset.

### Auxiliary Equipment Interface (A-Lead Control)

The system will detect an A-lead contact closure on certain incoming lines. When the system detects an A-lead contact closure by an external device connected to one of these lines, it causes a busy line light indication for this line to appear at all the stations in the system. The system does not send any A-lead signal to the external device connected to the line. Pressing the line select key on a system station cannot interrupt an external device providing the A-lead closure unless the line is programmed to be non-private.

### Auxiliary Station Ringer Interface

Refer to the discussion titled, Common Audible and Auxiliary Station Interface.

### Basic Key Service (1A2)

The system provides basic, 1A2 type features. Features such as selective line pickup, common line, hold, and multiline pickup and hold are available at every station.

### Battery Backup

The system programming is electronically protected during an AC power failure by a battery-like device called a "super-cap". The stored program data will remain in memory for a minimum of 30 hours after AC power fails or is disconnected. The system must be powered continuously for at least 30 minutes prior to the power failure or disconnection for memory preservation to occur.

### Busy Lamp Field Station (Option)

There is an optionally available 8-line telephone station equipped with 14 visual indicators adjacent to the memory keys. This station provides all of the available features in addition to a Busy Lamp Field (BLF) display. The visual indicators of this station display the status of the Direct Station Selection (DSS) intercom stations provided by the system at the key locations.

### Call Announce With Handsfree Answerback

The internal speaker at each station provides call-announce capability over the intercom link. A handsfree response to a call-announce call can be made. This response is transmitted by the microphone built into the handset.

### Call Transfer

Call transfer allows incoming calls to be transferred from one station to another, via the intercom link, in one of two ways. If both stations have access to the incoming line, a common line pickup transfer can be effected. If the other station does not have access to the incoming line, transfer can still take place using the system transfer feature. Some transfer considerations are as follows: If a transfer is attempted when there is no call on hold, the station being transferred to will receive the intercom dial tone, and the transferring station will be dropped from the intercom line. If a transfer is attempted and the station being transferred to does not answer the intercom call, the transferring station will reconnect to the call.

### Common Audible and Auxiliary Station Interface

Contact points are available which provide dry relay contact closures whenever an incoming line rings and whenever station 17 rings. The contact closures track the ringing pattern and can be used to control an external signalling device. When certain station ports are programmed to function as PA ports, these contact closures become enable contacts. They close when the PA port is called and can be used to enable an external PA system.

### Class Of Service Programming (From Main Station)

All class of service (COS) programming is performed from station 10. COS programming is used by the installer to configure and maintain the system, line, and station operating conditions.

### Class Of Service Printout (Model 616B KSU)

Class of service and toll restriction records are made available by the system as serial, ASCII data. It can be received and printed by any RS-232 compatible serial printer which is capable of operating at 110/300 baud. Communications are one-way to the printer only.

### Default Functional Program

At initial power up of the system, the operating features are set to a specific group of operating conditions (default conditions). The default conditions provide a complete operating system for use. It can be left as a defaulted system or reprogrammed as desired. Default conditions can be restored, if desired, by programming action.

### Dialing 0 For Attendant

The system attendant station (station 10) can be called whenever the 0 key is dialed on the intercom line.

### Distinctive Ringing

The ringing pattern of an incoming call follows the ringing pattern of the TELCO or PBX system. The ringing pattern of a tone signalled intercom call presents two tone bursts sounded every 4 seconds. A voice signalled intercom sounds two tone bursts one time.

### Do Not Disturb

Any station can be set to a do-not-disturb mode with the MONITOR key. While in this mode, the station will not ring on any incoming call nor will it accept an intercom call.

### DSS/BLF Console (Option)

The DSS/BLF Console is an optional console device designed to be a companion to a regular system station. It is useful with high call volume systems which require a dedicated call transfer location. The console provides 24-key direct station selection (DSS) intercom and an associated busy lamp field (BLF). It also provides one-key access to system-wide, all-call paging. The console is designed to be connected to any station port and serve as a companion to the station connected to the adjacent data-line paired port. Installation of this option to a system does not affect any features currently available to the companion station.



Dual Volume Controls (Speaker Output Level, Ringer loudness)

A faceplate mounted volume control on each station can be adjusted to set the audio level of the call announce speaker output. A bottom mounted volume control on each station can be adjusted to set the audio level of the tone ringer.

End To End Signalling (Off-Hook Dialing)

The system can generate DTMF tones from a dialing station, send them through the TELCO network, and have them received at the distant end for inward call completion at the distant system. This conventional, off-hook dialing mode can be performed from every station in the system.

Exclusive Hold

Pressing the HOLD key twice, when placing a call on hold, effects an exclusive hold condition. Exclusive hold links the held call to the timed hold recall timeout feature. Exclusive hold prohibits the held call from being picked up at any other station during the programmed timeout period. After timeout, audible and visual signalling will occur and the exclusive hold condition will revert to a normal line hold condition.

Fixed Direct Station Select (DSS) Intercom with Answer Hold

Each station comes equipped with a built-in direct station select intercom for stations 12 through 25. Access to these stations is effected by pressing the intercom select key and then pressing one of the memory keys. This action completes a voice announced intercom call to the selected station. Any active outside line is automatically placed on hold when the intercom select key is pressed.

Flash Operation/Dial Tone Recall

When custom calling features are available via a "flash" signal, the system can be programmed so that the RECALL key will generate a "flash" signal when it is pressed. When custom calling features are not available, the system can be programmed to allow the RECALL key to act as a positive disconnect or dial tone recall key. These two features are mutually exclusive. The system can be programmed to provide only one of these features at a time.

### Flexible Ringing Assignments (Delayed, Disabled, Subdued)

Flexible ringing assignments are programmable on a per line/per station basis. The system can be configured to provide direct ringing for every line at every station; direct ringing for prime line with delayed ringing for all other lines; and prime line ringing only. Ringing can be disabled for each line on an individual basis at each station. Subdued ringing is automatically provided to any station that is busy on an outside line.

### Hearing Aid Compatible Handset

The station handset is compatible with magnetically-coupled hearing aids.

### I Hold and I Use Indications

The light associated with the line select keys provide a visual indication of the in-use and hold status of each line available for use at a particular station.

### Intercom Call Progress Tones

Refer to the discussion titled, Tone or Voice Signalling (Intercom).

### Intercom Line Timeout

Should the intercom line be selected with no subsequent action taking place, the system will timeout the active status and return the station to an idle state.

### Last Number Redial

Each station is equipped with a last number redial feature. This feature will save the last number manually dialed from the keypad. It will redial the saved number upon key command. A newly dialed number will automatically replace a currently saved number.

### Line Preselection (Prime Line)

If a station is programmed to include a prime line, this line will be automatically selected for a manual dialing operation when the handset is taken off hook. If the prime line is busy, a manual line selection must be made.

Auto dial and speed dial numbers can be programmed to include any particular line desired. When this is done, an auto dial or speed dial operation automatically selects that line for dialing. Should that line be busy, manual line selection must be made. (If a line is selected manually for a speed dial call, either station or system, press the HOLD/SHIFT key before pressing the

speed dial key on the key pad.) If a particular line is not programmed for selection as part of the auto or speed dial, the prime line (if programmed) will be automatically chosen. If the prime line is unavailable or busy, the last line used to originate a call will be chosen.

Other than the prime line or the auto/speed dial line selection, automatic preselection of a line is not part of the system. A line can be manually selected before lifting the handset (for handsfree dialing) or after the handset is lifted. The key pad is automatically set for manual dialing when a manual line selection is made.

### Manual Hold

A key activated feature at each station will place a PBX or TELCO line on hold and provide music to the held party if an external music source is connected to the system.

Pressing the HOLD key once effects a normal timed hold condition. Any station which has access to the line can pick up the held call. The normal hold condition will hold a call for a programmed length of time. At the end of the first timeout period, the line select indicator will flutter rapidly at all stations and three quick tone bursts will sound at the holding station. At the end of each subsequent timeout period, the holding station receives an additional three quick tone bursts.

### Memory Dialing Features (Programmable Keys, Speed Dial)

Each station provides programmable memory dialing features available in a 14-key configuration. These memory keys can be programmed to store numbers for automatic dialing purposes. The stored numbers can be up to 15-digits in length and can include line or intercom selection, numbers, #'s, \*, pauses, and flash signals. A pause is stored each time the HOLD key is pressed, and a flash signal is stored each time the RECALL key is pressed. The pause and flash intervals are programmable. Alternately, memory location 14 can provide automatic, repetitive dialing of the last number dialed if a memory number is not stored at that location.

Each station can be programmed to provide 10 speed dial numbers at the keypad keys. Speed dial numbers can be up to 15-digits in length and also can include line or intercom selection, numbers, #'s, #'s, \*, pauses, and flashes. In addition to the station speed dial numbers, 10 system-wide speed dial numbers are available at the keypad keys. The system speed dial numbers can be up to 31 digits in length, and can include the same information as described above. System speed dial programming can only be done at station 10.

### Mixed Station Capacities

The system will support a mixture of 3-line and 8-line telephone stations. These stations can be standard stations or optional speakerphones.

### Modular Wiring and Jacks/4-Conductor Wire System

The system can be completely interconnected by employing industry standard 50-pin connectors and modular plug/jack combinations. Station wiring is small, 4-conductor, twisted-pair cable throughout the system.

### Momentary Keys with LED Indicators

The station keys are momentary contact, press and release types. They provide line selection, call monitoring, and other feature selection. Visual indication of the feature selection is provided by built-in light emitting diodes (LEDs).

### Multiline Conferencing

This system feature will allow one or more stations to access two outside lines at the same time resulting in a multipath conversation. The voice reception at the distant parties' stations is dependent upon the quality of the outside lines. If more than one internal station is added to the conference, the voice levels will be lower than when a single internal station is involved.

### Music-On-Hold/Music Interface (External Source)

A jack is provided on the KSU for the connection of a KX registered music source. This music source places music on TELCO and PBX lines that are placed on hold.

### Mute

Each station has a feature key which will mute the handset transmitter or internal microphone (on speakerphones) to prohibit the user's voice from being heard by the distant party.

### Night Transfer (Of Ringing)

The night transfer mode automatically transfers the ringing of all incoming calls to a particular station or stations for off-hour or special purpose answering. The night transfer mode can only be made active from station 10.

### Non-Square System/Tenant Service

A system can be programmed to be a square system or a non-square system as desired. In a square system, the line 1 select key of the telephone station selects line 1, the line 2 key selects line 2, etc. In a non-square system, each line select key selects the available line specified by COS programming. In tenant service, the non-square system provides all sharing users with the use of the same line select keys while enabling these keys to select different assigned lines.

### On-Hook Dialing/Call Monitor

Every station can provide on-hook manual and automatic dialing. An internal speaker monitors the placed call for completion. The handset must be taken off-hook to provide the voice link on nonspeakerphone stations.

### Originating Denied

The ability to originate calls on certain available lines can be denied at certain stations through system programming. The originating denied feature is programmed on a per station/per line basis. Originating denied does not prevent a user from answering a ringing line.

### PBX/Centrex/Central Office Compatible

The system features and programmable options are compatible with the requirements of PBX, CENTREX, and Central Office operation. Numbers, #'s, \*'s, and programmable pauses can be made a part of every stored number for automatic and speed dial. Additionally, a custom calling features access/dial tone recall feature is available to provide a programmable time interval "flash" signal for custom calling features access or a line disconnect for dial tone recall. The station hookswitch also provides a line disconnect when it is actuated. This feature will provide dial tone recall on stations with a programmed prime line.

### Power Failure Transfer

A special voice pair is available for connecting a non-electronic telephone such as an industry standard model 2500. This voice pair is automatically connected directly to line 1 whenever there is an AC power failure. Call out and incoming ringing on this power failure station is possible during the power failure condition. The power failure station will automatically disconnect as soon as power is restored.

### Power On Visual Indication

The KSU has a red LED which provides an AC power on indication and monitors the status of the system.

Prime Line

Refer to the discussion titled, Line Preselection (Prime Line).

Privacy Release

When the automatic privacy feature is active, all other stations are excluded from joining a station on an active line unless that station allows it. The privacy release feature allows a station user to release automatic privacy so that other stations can be added to an active call.

Programmable Keys

Refer to the discussion titled, Memory Dialing Features.

Programmed Direct Station Select (DSS)

A station user can store an intercom line selection and a station number at a memory key location to create a DSS memory key. When this key is pressed, an active outside call is automatically placed on hold and a voice signalled intercom call is automatically made to that previously stored station number.

Pull Out Directory

Each station is equipped with a pull out directory. This directory can be used for recording the system speed dial and station speed dial numbers.

Pulse/Tone Switchable

The system can be programmed on a per line basis to allow the stations to switch from pulse to DTMF tone dialing as needed. Alternately, the system can be programmed to only allow DTMF tone dialing.

Ringling Line Preference

The system can be programmed on a per station basis to enable ringing line preference. When ringing line preference is enabled at a station, taking it off-hook will automatically connect it to an outside line which has audible ringing. A line select key will not have to be pressed.

Saved Number Redial

This feature enables a key action to save the last number manually dialed from the keypad. The same key action will redial the saved number when it is pressed at a later time. The saved number is permanently available for later use until it is replaced with a new number.

### Self Diagnostics

Each station can execute a self test when so enabled.

### Speakerphone (Option)

The optional speakerphone provides operation of all features except voice signalled intercom calls with the handset on-hook. The handset must be lifted for this one purpose.

### Speed Dial

Refer to the discussion titled, Memory Dialing Features.

### Timed Hold Recall

The system programming selects the timeout period for a call on hold. When a held call exceeds the timeout period, the system audibly signals the condition to the station that placed the call on hold. It also visually signals all other stations. The audible signal is repeated at the end of each time out period. The visual indication continues until the held call is picked up.

### Toll Restriction - 0 and 1 (Model 616 KSU)

System programming can be configured to prohibit some or all stations from calling, on certain lines, any number prefixed with a 1 or a 0. The feature works as follows: Each line can be programmed to be either a restricted or a non-restricted TELCO or PBX line. Each station can be programmed so that it cannot dial a 1, a 0, or both on any restricted line. This programming does not prevent that station from dialing 1 and/or 0 on a non-restricted line. Numbers such as 1-800-xxx-xxxx are not restricted in any manner. When the station is restricted from dialing 1, it is also restricted from dialing 411 on a TELCO line or PBX line. On PBX lines, the 1 and 0 dialing restriction is activated after the single digit access code has been dialed. Dialing a restricted number on a restricted line will cause the line to be automatically disconnected for 2 seconds.

### Toll Restriction - Expanded (Model 616B KSU)

System toll call restriction can be configured, by Class Of Service programming, to prohibit some or all stations from calling a wide range of number combinations. The restricted numbers are specified on programmable restricted number tables which are assigned on a per station and per line basis.

In general, toll restriction works as follows: The programmable tables of restricted numbers contain entries of up to 16 digits each. Each table of restricted numbers can be programmed to be an "allow" table or a "deny" table. Entries in an "allow" table override entries in a "deny" table. This feature allows exceptions to toll restriction to be enabled. For example, the

dialing of all 1-xxx-xxx-xxxx numbers can be denied while the dialing of 1-800-xxx-xxxx numbers is enabled. A "match anything" symbol (#) can be stored to represent any digit from 1 to 0. The programmed toll restriction tables are individually assigned to each station and line through COS programming.

When a line selection is made and a station is dialed, the system examines the dialed number and makes a comparison between the station toll restriction tables and the line toll restriction tables. Any tables assigned to BOTH the station being used and the selected line determine the toll restrictions to be imposed. Dialing a restricted number on a restricted line from a restricted station will cause the line to be automatically disconnected for 2 seconds.

#### Tone or Voice Signalling (Intercom)

The intercom feature links the stations of the system together. Three intercom paths are available on the Model 616B KSU, and two paths are available on the Model 616 KSU. Intercom calls can be tone signalled or voice announced as desired, and can be responded to in a handsfree manner. Intercom call progress is marked by special tone signals. A visual indication is presented when all of the paths are busy.

#### Wall Mounting Adapter (Station)

A special adapter is available which will allow a station to be mounted on a wall.

#### Zone Paging (616B KSU)

Refer to the discussion titled, All-Call and Zone Paging (Via Station Speakers).

#### SPECIFICATIONS

The general specifications of the Model 616B and 616 electronic key system are shown in Table 1.



Table 1. General Specifications

<b>System Capacity —</b>	
Co Lines	6
Stations	16
Intercom Links	2 (616)
	3 (616B)
Paging Link	1 (616B)
<b>Power Dissipation —</b>	
KSU and power supply @ 117VAC nominal, fully loaded system	55 watts
<b>Dimensions and Weights —</b>	
KSU width (inches)	15½
height	24
depth	3½
KSU pounds	22
<b>Keypad footprint (inches)</b>	7¾ x 8½
<b>Keypad pounds (lb-oz)</b>	2-10
<b>Cable Requirements —</b>	
Station cable, 2-pair twisted, non-shielded 24AWG	
Maximum cable length 1500 feet	
<b>A-Lead Control Loop Limits</b>	
Maximum Resistance of 1500 Ohms	
<b>Power Requirements —</b>	
KSU and power supply	
Input: 117 VAC ± 10% 0.4 AMPS, 60 Hz, single phase	
<b>Switching Principle —</b>	
Solid state, space division, analog switching with stored program control.	
<b>Operating Environment —</b>	
Temperature: 32-120° F (0° -49° C)	
Humidity 90% relative, noncondensing	
<b>Industry/Regulatory Standards —</b>	
FCC certified, part 15a	
FCC registered, part 68	
UL Listed (in process)	
EIA RS478, Bell Pub 48002 guidance	
Hearing aid compatible	
<b>Termination for Outside Lines —</b>	
Individual, 623 — type, four-conductor minijacks: USOC's RJ11C (or RJ12C with A/A1 leads for lines 5 or 6).	
<b>Termination for Stations —</b>	
25-pair connector for connection to external distribution field.	
<b>Central Office Limits —</b>	
Maximum 1900 OHMS loop, minimum 15,000 OHMS cable insulation leakage.	
<b>CO/PBX Line Ringer Equivalence Number —</b>	
REN 0.3B	
<b>FCC Registration Number —</b>	
CVW7WC-12829-KF-E	
<b>Printer Port (Model 616B KSU Only)</b>	
Format: Serial, pseudo RS-232C (transmit only)	
Parity: None	
Data Bits: 7	
Stop Bits: 2	
Baud Rate: 300/110 COS programmable	
Handshaking Requirements: CTS (if available) from printer to KSU	
RTS (if needed) from KSU to printer	
Printer Cable Length: 50 feet maximum from KSU to printer	

## SECTION 2

INSTALLER/USER INFORMATION  
REGARDING FCC RULES AND REGULATIONS

This electronic key system complies with Federal Communications Commission (FCC) Rules, Part 68.

The FCC registration label on the KSU contains the FCC registration number, the ringer equivalence number, the model number, and the serial number or production date of the system.

## NOTIFICATION TO TELEPHONE COMPANY

Unless the telephone operating company provides and installs the system, the telephone operating company must be notified before a connection is made. The lines (telephone numbers) involved, the FCC registration number, and the ringer equivalence must be provided to the telephone company. The FCC registration number and the ringer equivalence number of this equipment are provided on the label attached to the KSU.

The user is required to notify the telephone company when final disconnection of this equipment from the telephone company line occurs.

## COMPATIBILITY WITH TELEPHONE NETWORK

When necessary, the telephone operating company provides information on the maximum number of telephones or ringers that can be connected to one line, as well as any other applicable technical information. The telephone operating company can temporarily discontinue service and make changes which could affect the operation of your equipment. They must, however, provide adequate notice, in writing, of any future equipment changes that would make the system incompatible.

## INSTALLATION REQUIREMENTS

Connection of the electronic key system to the telephone lines must be through universal service order code (USOC) outlet jacks supplied by the telephone operating company. If the installation site does not have the proper outlets, ask the telephone company business office to install new outlets or adapters for the present ones. The correct outlet jacks for this system are type RJ11C or RJ12C jacks.

## PARTY LINES AND COIN LINES

Local telephone company regulations may not permit connections to party lines and coin lines by anyone except the telephone operating company.

## TROUBLESHOOTING

If a service problem occurs, first try to determine if the trouble is in the on-site system or in the telephone company equipment. Disconnect all equipment not owned by the telephone company. If this corrects the problem, the faulty equipment must not be reconnected to the telephone line until the problem has been corrected. Any trouble that causes improper operation of the telephone network may require the telephone company to discontinue service to the trouble site after they notify the user of the reason.

## REPAIR AUTHORIZATION

FCC regulations do not permit repair of customer owned equipment by anyone except the manufacturer or their authorized agent and by others who might be authorized by the FCC. However, routine repairs can be made according to the maintenance instructions in this publication, provided that all FCC restrictions are obeyed.

## RADIO FREQUENCY INTERFERENCE

The electronic key system contains incidental radio frequency generating circuitry and, if not installed and used properly, may cause interference to radio and television reception. This equipment has been tested and found to comply with the limits for a Class A computing device pursuant to Subpart J of Part 15 of FCC Rules. These limits are designed to provide reasonable protection against such interference when operated in a commercial environment.

Operation of this equipment in a residential area may cause interference to radio and television reception; in which case, the user is encouraged to take whatever measures may be required to correct the interference.

If this equipment does cause interference to radio or television reception, which can be determined by turning the equipment off and on, the user is encouraged to try to correct the interference by one or both of the following measures: Reorient the television or radio's receiving antenna. Relocate the KSU, the individual telephone stations, and the radio or TV with respect to each other.

If necessary, the user should consult the manufacturer or an experienced radio/television technician for additional suggestions. The user may find the following booklet prepared by the Federal Communications Commission helpful: "How to Identify and Resolve Radio-TV Interference Problems." This booklet is available from the Government Printing Office, Washington D.C. 20402. Stock No. 004-000-00345-4.

#### RINGER EQUIVALENCE NUMBER

The REN of each line of the KSU is 0.3B. The FCC requires the installer to determine the total REN for each line, and record it at the equipment.

## CHAPTER 2 INSTALLATION

### MOUNTING CONSIDERATIONS

#### KSU Mounting

The KSU cabinet should be attached vertically to any sturdy, flat, surface. It may be vertically rack mounted if desired. It must be located within 6 feet of a properly grounded, three-wire, 117VAC, electrical outlet. The distance between the KSU and the TELCO/PBX jacks must be 25 feet or less as per FCC requirements. A nominal distance of 7 feet is recommended.

Choose a secure, dry mounting location with adequate ventilation. The temperature range of the location must be within 32-120 degrees F (0-49 degrees C). If the mounting surface is damp or if it is concrete or masonry material, a backboard must be attached to the mounting surface to be used for KSU mounting. Suitable mounting backboards are available commercially or can be constructed out of 1/2-inch plywood cut to size.

Tools and hardware required for mounting the KSU cabinet include: 1/4 x 1-inch round head wood screws, toggle bolts, or wall anchors and fasteners; a screwdriver; an electric drill if prepared holes are required; and a connecting tool for fastening wires to a type-66 connector block.

1. A full scale mounting template is supplied in the KSU packing box. Hold or tape this template to the mounting surface, and mark the location of the mounting holes on the mounting surface as they are located on the template. The KSU mounting dimensions are as shown on Figure 1.
2. Drill holes in the mounting surface of a proper size to accommodate the hardware being used. If necessary, prepare these holes with inserts, anchors or other attachment devices as dictated by the type of mounting surface.
3. Attach the KSU to the mounting surface with four (4) screws installed through the KSU mounting flange and into the mounting surface holes. Note that the flange holes are elongated with an enlargement at one end of the hole. This feature allows the mounting screws to be partially installed in the mounting surface before the KSU is hung on them.

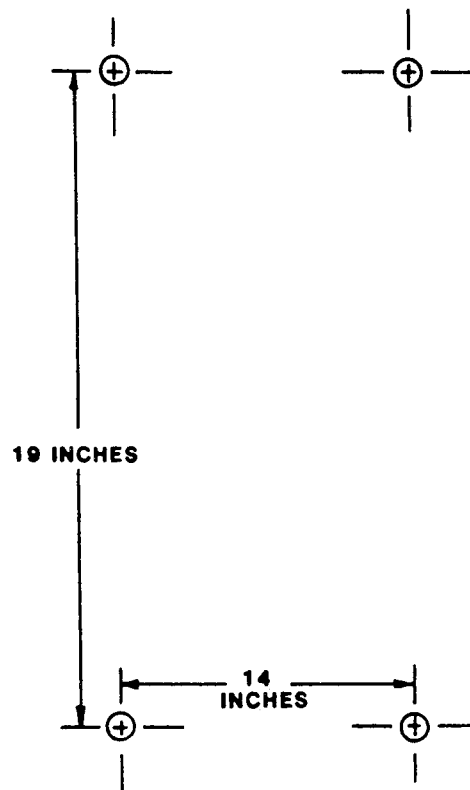

Figure 1. KSU Mounting Dimensions

### Telephone Set Mounting

Place the individual telephone stations as desired and in keeping with accepted industry and office standards.

A telephone station can be wall mounted if necessary. Use a wall mounting bracket (part number 701032-056) for this purpose.

### CABLE ROUTING

Cable may be routed concealed or visible as the installation location requires. Good engineering practices must be observed and all applicable building codes must be adhered to.

- The maximum distance allowed from the KSU to the station is 1500 feet using #24 gauge, twisted-pair cable.
- The allowed tip/ring loop resistance is 1900 ohms from the jack to the TELCO/PABX equipment.

## CONNECTIONS

Line Connections

Connection between the KSU and the TELCO or PABX line is via four-wire cable and modular plug/jack connection. The maximum length of a line cable is determined by the limitations detailed above.

## A-Lead Control

The KSU inputs of TELCO lines 5 and 6 are configured to detect an A-lead (A and A1) control signal when it is applied at the TELCO input to the KSU. A typical use of A-lead control signal detection would find a single-line, non-key system, telephone set, modem, data terminal, etc. configured for A-lead control and connected to the line ahead of the KSU. When the KSU detects an A-lead control signal on line 5 or 6, it causes a busy indication to be shown at all key system stations connected to the line. Pressing the line select key on a station cannot interrupt the externally connected A-lead device unless the system is programmed to make the line non-private. The A-lead loop resistance must not exceed 1500 ohms.

The A-lead control connections are available at clip terminals 42 - 43 (line 5) and 47 - 48 (line 6) on the station connector block that is connected to J2 of the KSU.

Station Connections

Connections between the KSU and the stations are typically via two 66M-xx station distribution connector blocks per the discussion steps given below. Refer to Figures 3 and 4 for connection details. Various types of station distribution connector blocks are available and may be used in lieu of the type 66M-xx connector if desired.

## IMPORTANT NOTE

THE SYSTEM PROVIDES ONE TIP AND RING PAIR CONNECTED TO LINE 1 AS AN EMERGENCY, POWER FAILURE CIRCUIT. THIS POWER FAILURE PAIR IS LOCATED AS DETAILED ON FIGURE 3 AND 4. THE POWER FAILURE PAIR IS ONLY ACTIVE DURING A POWER FAILURE. AN INDUSTRY STANDARD, SINGLE-LINE TELEPHONE, SUCH AS A TYPE 2500, CAN BE CONNECTED TO THIS PAIR AND USED TO PROVIDE COMMUNICATIONS CAPABILITY SHOULD THE AC POWER TO THE SYSTEM BE INTERRUPTED.

1. Connect a cable between the KSU connector and the connector on the 66M-xx connecting block.
2. Connect four-wire, twisted-pair cables from the 66M-xx block directly to the station or from the 66M-xx block to modular RJ14 configuration station jacks.

**CAUTION**

The polarity between the individual wires in a particular voice or data pair is not critical; however, do not connect the voice circuits to the data circuits. Doing so will make a pair of stations inoperative.

3. After making the wiring connections discussed above and illustrated in Figures 2, 3 and 4, double check all connections and cable routing to insure accuracy.

**Printer Connection** (Model 616B KSU)

When a serial data printer is used for COS printout, connect it to clips 41, 42, 43, and 44 of station connector block J1. Transmitted data, signal ground, request-to send, and clear-to-send terminations are supplied at the connector block by the KSU. Signal levels meet RS-232 specifications. A typical connection configuration is as illustrated in Figure 3. The maximum distance between the printer and the KSU must not exceed 50 feet. When preparing a cable for connection to the printer interface connector, refer to the manufacturer's manual applicable to the printer being interfaced, and make the following wiring connections:

- Wire the TD line (data to printer from KSU - clip 41) to the printer receive data input pin.
- Wire the SG line (signal ground - clip 42) to the printer signal ground pin.
- Wire the RTS line (status signal from the KSU to the printer - clip 43) to the printer data-set-ready input pin.
- Wire the CTS line (status from printer to KSU - clip 44) to the printer request-to-send output pin.

Configure the printer, per the manufacturer's instructions, to receive 7-bit serial data with 2 stop bits and no parity bit. Set the baud rate for the serial data at 110 or 300 baud. The printer baud rate setting must match the system baud rate set by COS programming. The system defaults to a baud rate of 110.



### AC Power

To apply AC power to the KSU, connect the AC power cord to a properly grounded, three-wire, 117VAC electrical outlet. A plug-in, power line surge protector should be installed between the KSU power cord and the AC outlet. Many different models of surge protectors are commercially available for this purpose.

### System Grounding

It is recommended that a grounding wire, separate from the three wire AC line cord, be used. Some local codes may require this use. A ground stud is located at the lower right corner of the KSU for this purpose. Wire a #10 or #12, insulated, solid copper wire between this ground stud and a reliable earth ground such as a metal cold water pipe or a building frame ground.

### External Signalling

Two sets of connection points are available which provide relay contact closures for external use. One set provides a relay contact closure whenever any of the TELCO lines, connected to the KSU, ring. The other set provides a relay contact closure whenever system station 17 rings. The provided contact closures track the ringing pattern in both cases. The contacts are closed during the ring on period and are open during the silent period. A typical connection to these terminals is illustrated in Figure 2a (model 616B) and Figure 2b (model 616). The function of these control terminals can be changed by system programming. Refer to the paragraph headed Dial Access Public Address (PA) Port for a discussion of the alternate function.

- On Model 616B systems, the contact points are clip terminals 45 - 46 (common audible) and 47 - 48 (station 17 audible) located on the station connector block that is connected to J1 on the KSU.
- On Model 616 systems, the contact points are screw terminals 1 - 2 (common audible) and 3 - 4 (station 17 audible) located on the KSU screw-type terminal strip.

#### **CAUTION**

Do not exceed a 0.4 amps at 24 volts load on these connection points. If the load requirements exceed this limit, connect the load through an external relay. DO NOT CONNECT THE CONTACTS DIRECTLY TO THE 117VAC LINE.

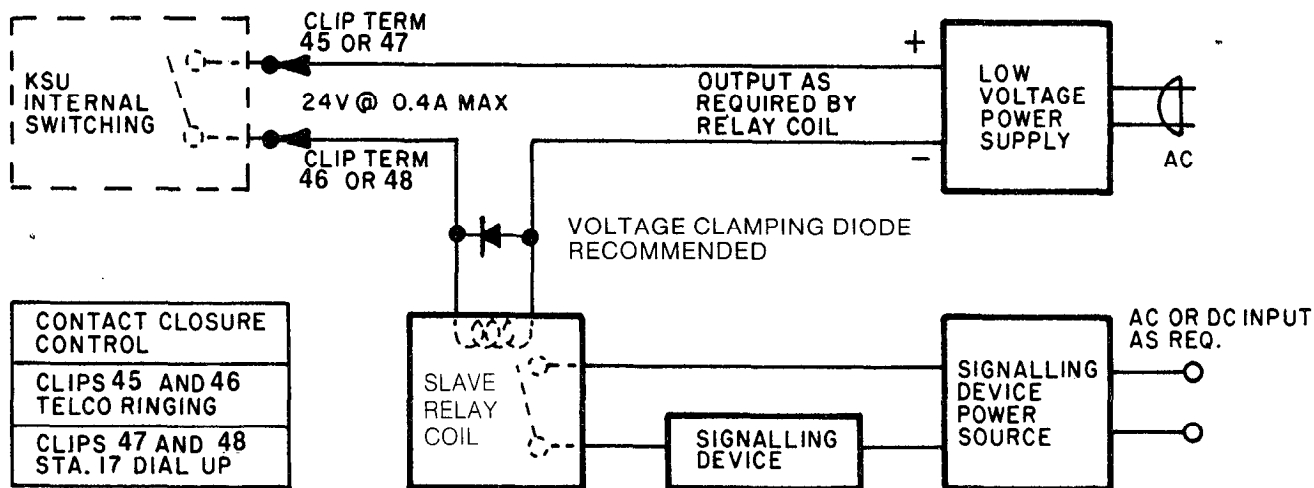

Figure 2a. Model 616B External Signalling - Typical Connection

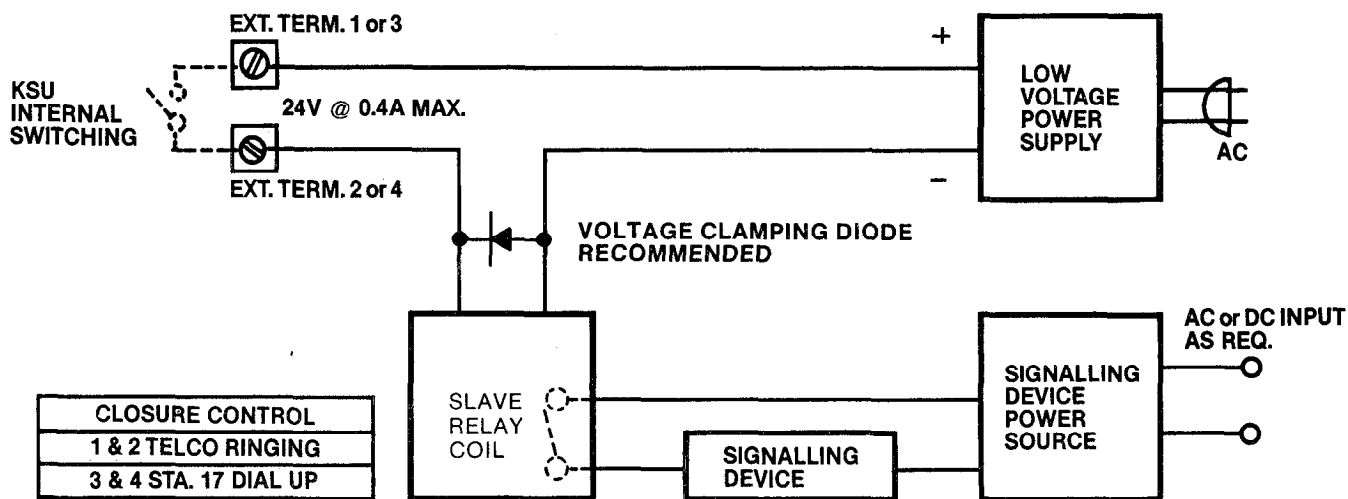
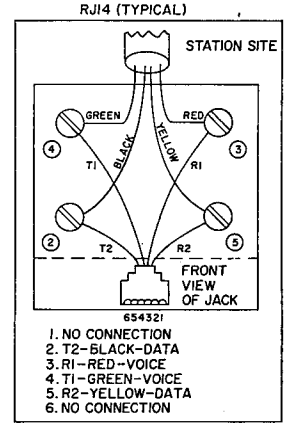
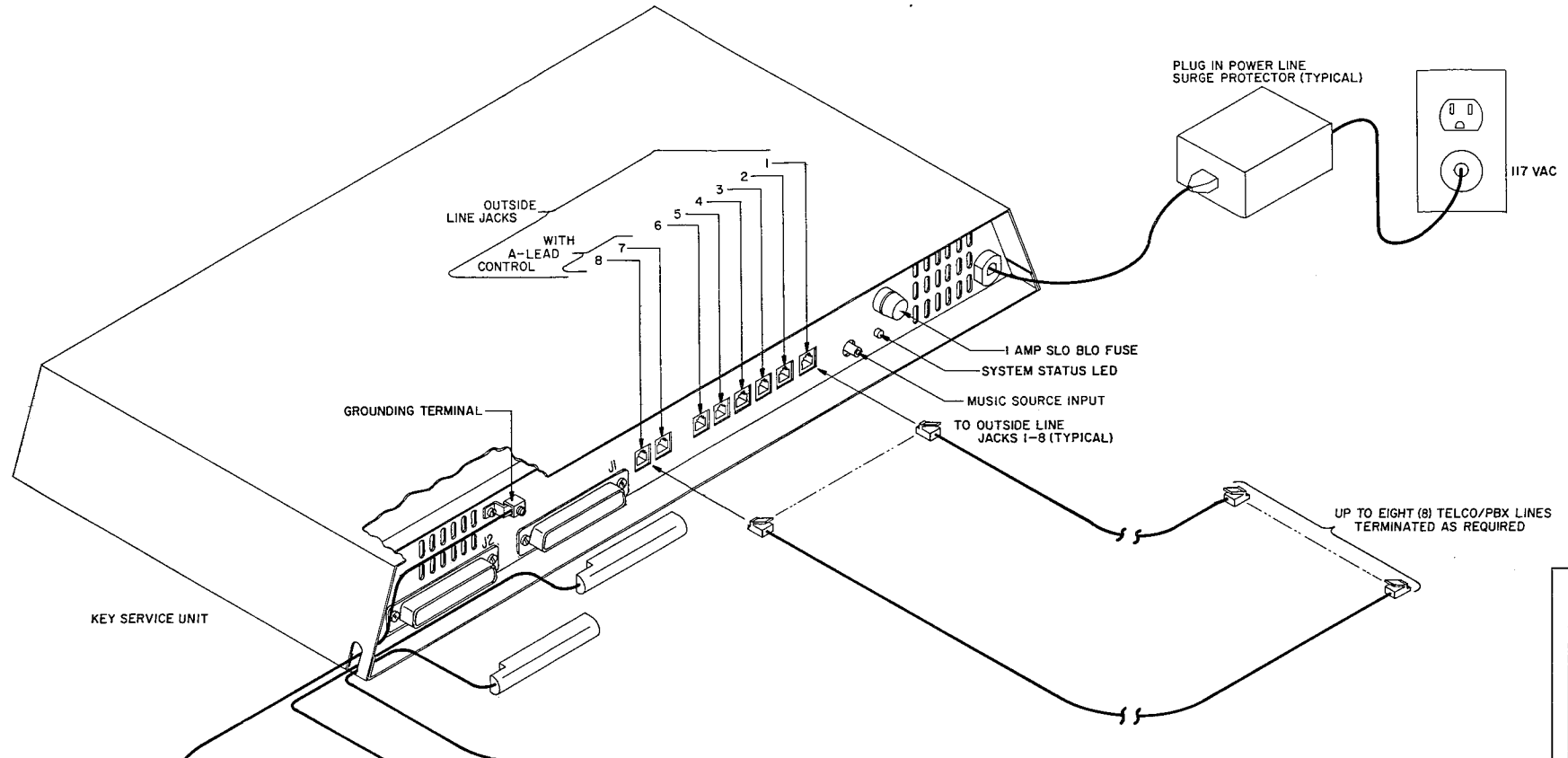

Figure 2b. Model 616 External Signalling - Typical Connection

STATION CONNECTIONS

25 PAIR CABLE FROM J1, J2	AMP CONN PIN NO	CONNECTION BLOCK FOR J1	CONNECTION BLOCK FOR J2	STATION CABLE WIRING
WIRE COLOR PAIR	STA. NO. ASSIGNMENT	STA. NO. ASSIGNMENT	STA. NO. ASSIGNMENT	COLOR CLIP TERM
WHITE-BLUE	1	10	20	GREEN 1
BLUE-WHITE	1	10	20	RED 2
WHITE-ORANGE	2	10	20	YELLOW 3
ORANGE-WHITE	2	10	20	BLACK 4
WHITE-GREEN	3	11	21	GREEN 5
GREEN-WHITE	3	11	21	RED 6
WHITE-BROWN	4	11	21	YELLOW 7
BROWN-WHITE	4	11	21	BLACK 8
WHITE-SLATE	5	12	22	GREEN 9
SLATE-WHITE	5	12	22	RED 10
RED-BLUE	6	12	22	YELLOW 11
BLUE-RED	6	12	22	BLACK 12
RED-ORANGE	7	13	23	GREEN 13
ORANGE-RED	7	13	23	RED 14
RED-GREEN	8	13	23	YELLOW 15
GREEN-RED	8	13	23	BLACK 16
RED-BROWN	9	14	24	GREEN 17
BROWN-RED	9	14	24	RED 18
RED-SLATE	10	14	24	YELLOW 19
SLATE-RED	10	14	24	BLACK 20
BLACK-BLUE	11	15	25	GREEN 21
BLUE-BLACK	11	15	25	RED 22
BLACK-ORANGE	12	15	25	YELLOW 23
ORANGE-BLACK	12	15	25	BLACK 24
BLACK-GREEN	13	16	SPARE	GREEN 25
GREEN-BLACK	13	16	SPARE	RED 26
BLACK-BROWN	14	16	SPARE	YELLOW 27
BROWN-BLACK	14	16	SPARE	BLACK 28
BLACK-SLATE	15	17	SPARE	GREEN 29
SLATE-BLACK	15	17	SPARE	RED 30
YELLOW-BLUE	16	17	SPARE	YELLOW 31
BLUE-YELLOW	16	17	SPARE	BLACK 32
YELLOW-ORANGE	17	18	SPARE	GREEN 33
ORANGE-YELLOW	17	18	SPARE	RED 34
YELLOW-GREEN	18	18	SPARE	YELLOW 35
GREEN-YELLOW	18	18	SPARE	BLACK 36
YELLOW-BROWN	19	19	SPARE	GREEN 37
BROWN-YELLOW	19	19	SPARE	RED 38
YELLOW-SLATE	20	19	SPARE	YELLOW 39
SLATE-YELLOW	20	19	SPARE	BLACK 40
VIOLET-BLUE	21	TD	FROM	TIP GREEN 41
BLUE-VIOLET	21	DATA	GND.	RING RED 42
VIOLET-ORANGE	22	RTS	TELCO	RED 43
ORANGE-VIOLET	22	PRINT	LINE 7	A1 BLACK 44
VIOLET-GREEN	23	CTS	FROM	TIP GREEN 45
GREEN-VIOLET	23	COMM	TELCO	RING RED 46
VIOLET-BROWN	24	AUDIB.	CONTACT	A YELLOW 47
BROWN-VIOLET	24	STA 17	TELCO	A1 BLACK 48
VIOLET-SLATE	25	AUDIB.	CONTACT	A YELLOW 47
SLATE-VIOLET	25	POWER	LINE 8	A1 BLACK 48
		FAIL	TIP	GREEN 49
			RING	RED 50



- NOTES
- (1) TYPICAL CONNECTING BLOCK SHOWN. OTHER TYPES OF STATION DISTRIBUTION CONNECTING BLOCKS ARE AVAILABLE AND MAY BE USED IN LIEU OF THE 66M-XX TYPE
  - (2) ALL STATION CABLE IS TWISTED-PAIR FOUR-WIRE FROM THE 66-XX BLOCK TO THE RJ14 JACK
  - (3) MAXIMUM DISTANCE BETWEEN KSU AND SERIAL PRINTER IS LIMITED TO 50 FEET
  - (4) STRAP CTS TO RTS AT CONNECTOR BLOCK IF CTS IS NOT USED BY DATA PRINTER

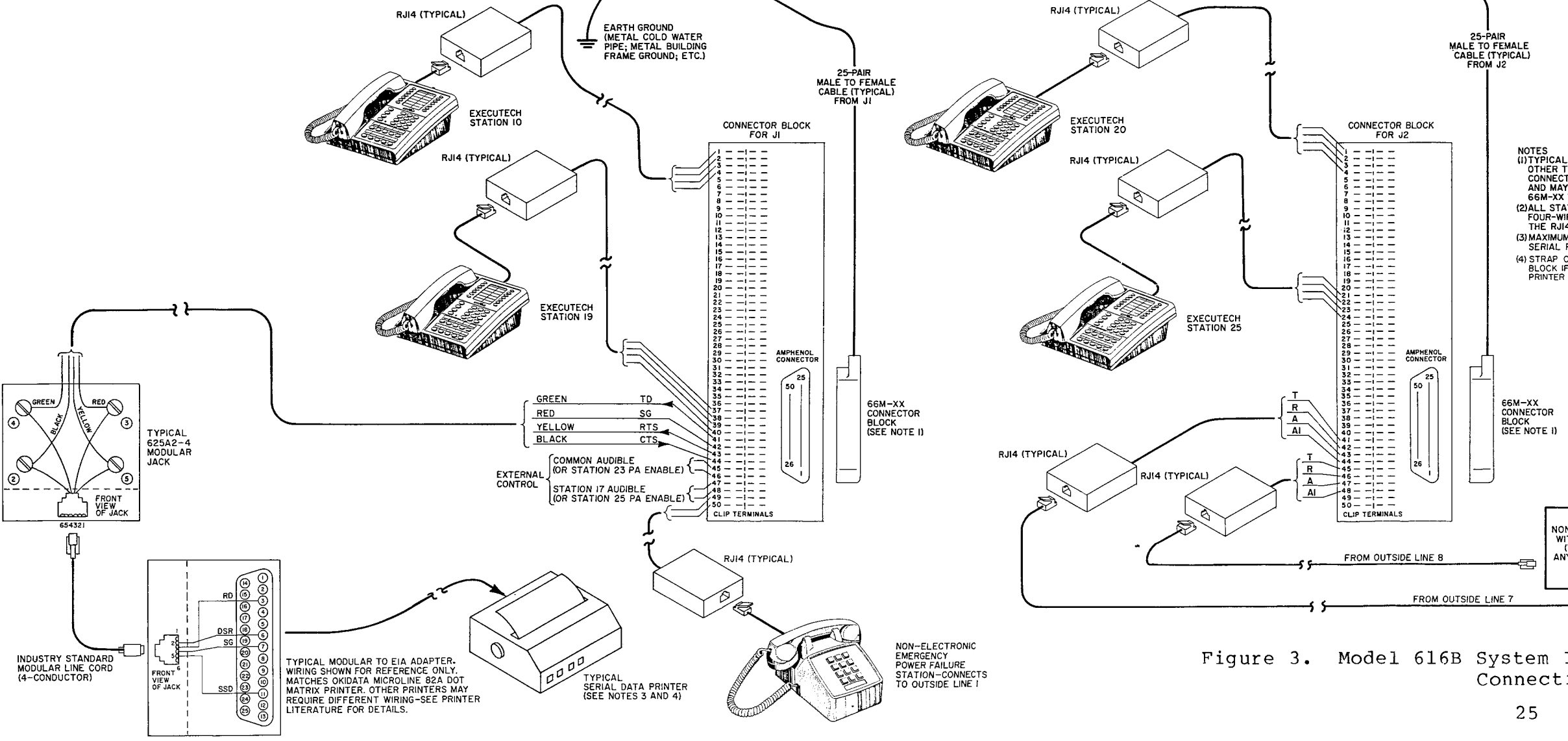
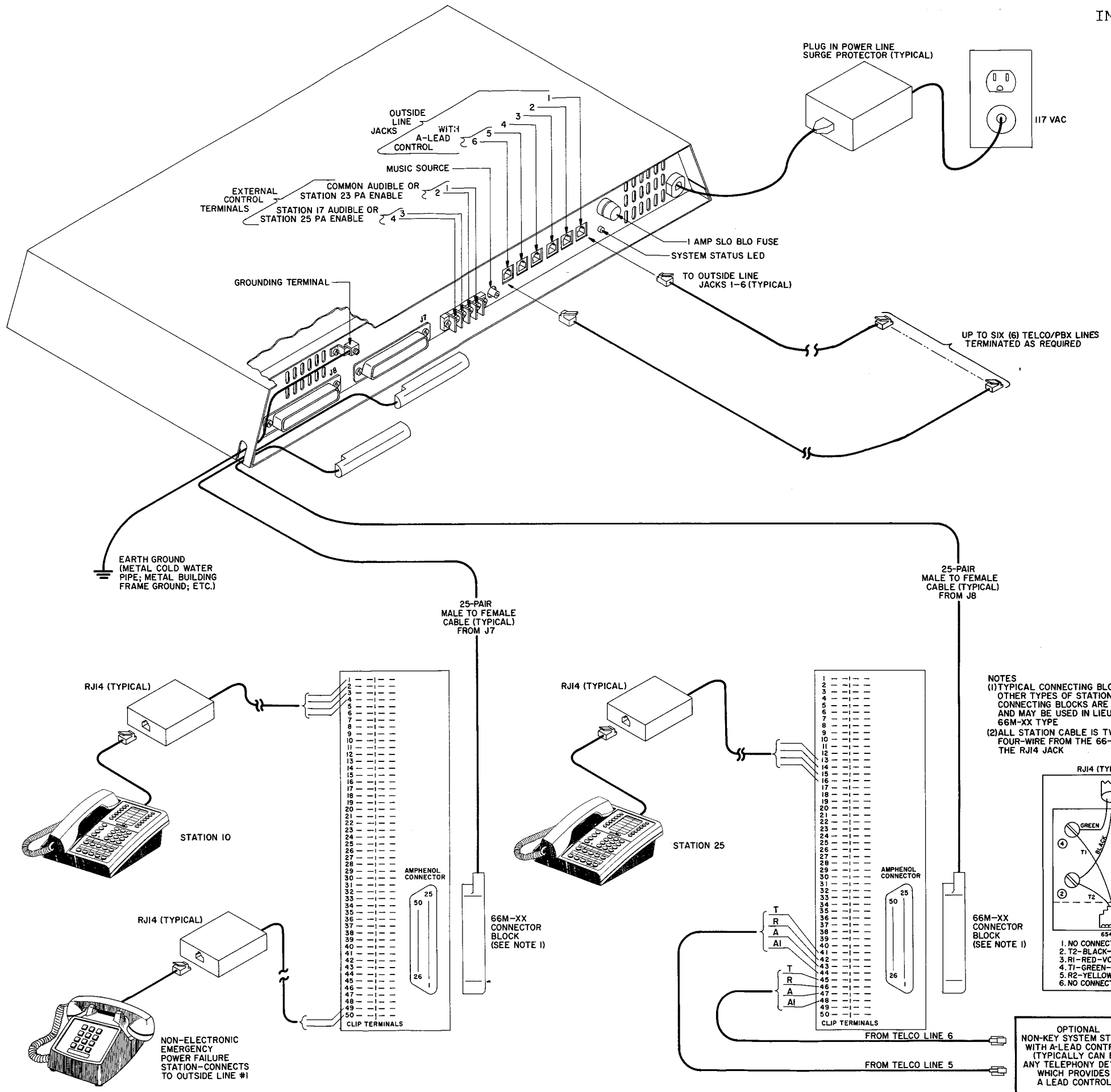
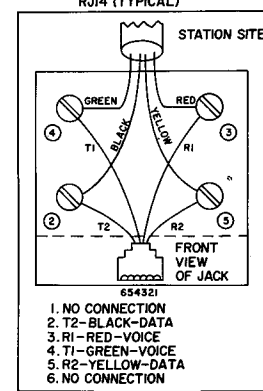

Figure 3. Model 616B System Interconnection - Typical Connections

CONNECTION BLOCK FOR J1		CONNECTION BLOCK FOR J2		STATION CABLE WIRING		25 PAIR CABLE FROM J1 & J2	
STA. NO.	ASSIGNMENT	STA. NO.	ASSIGNMENT	COLOR	CLIP TERM. NO.	WIRE COLOR	PAIR
10	VOICE PAIR	22	VOICE PAIR	GREEN	1	WHITE-BLUE	1
	DATA PAIR		DATA PAIR	RED	2	BLUE-WHITE	2
	DATA PAIR		DATA PAIR	YELLOW	3	WHITE-ORANGE	3
11	VOICE PAIR	23	VOICE PAIR	BLACK	4	ORANGE-WHITE	4
	DATA PAIR		DATA PAIR	GREEN	5	WHITE-GREEN	5
	DATA PAIR		DATA PAIR	RED	6	GREEN-WHITE	6
12	VOICE PAIR	24	VOICE PAIR	YELLOW	7	WHITE-BROWN	7
	DATA PAIR		DATA PAIR	BLACK	8	BROWN-WHITE	8
	DATA PAIR		DATA PAIR	GREEN	9	WHITE-SLATE	9
13	VOICE PAIR	25	VOICE PAIR	RED	10	SLATE-WHITE	10
	DATA PAIR		DATA PAIR	YELLOW	11	RED-BLUE	11
	DATA PAIR		DATA PAIR	BLACK	12	BLUE-RED	12
14	VOICE PAIR	SPARE	VOICE PAIR	GREEN	13	RED-ORANGE	13
	DATA PAIR		DATA PAIR	RED	14	ORANGE-RED	14
	DATA PAIR		DATA PAIR	YELLOW	15	RED-GREEN	15
15	VOICE PAIR	SPARE	VOICE PAIR	BLACK	16	GREEN-RED	16
	DATA PAIR		DATA PAIR	GREEN	17	RED-BROWN	17
	DATA PAIR		DATA PAIR	RED	18	BROWN-RED	18
16	VOICE PAIR	SPARE	VOICE PAIR	YELLOW	19	RED-SLATE	19
	DATA PAIR		DATA PAIR	BLACK	20	SLATE-RED	20
	DATA PAIR		DATA PAIR	GREEN	21	BLACK-BLUE	21
17	VOICE PAIR	SPARE	VOICE PAIR	RED	22	BLUE-BLACK	22
	DATA PAIR		DATA PAIR	YELLOW	23	BLACK-ORANGE	23
	DATA PAIR		DATA PAIR	BLACK	24	ORANGE-BLACK	24
18	VOICE PAIR	SPARE	VOICE PAIR	GREEN	25	BLACK-GREEN	25
	DATA PAIR		DATA PAIR	RED	26	GREEN-BLACK	26
	DATA PAIR		DATA PAIR	YELLOW	27	BLACK-BROWN	27
19	VOICE PAIR	SPARE	VOICE PAIR	BLACK	28	BROWN-BLACK	28
	DATA PAIR		DATA PAIR	GREEN	29	BLACK-SLATE	29
	DATA PAIR		DATA PAIR	RED	30	SLATE-BLACK	30
20	VOICE PAIR	FROM TELCO LINE 5	TIP	YELLOW	31	YELLOW-BLUE	31
	DATA PAIR		RING	BLACK	32	BLUE-YELLOW	32
	DATA PAIR		A	GREEN	33	YELLOW-ORANGE	33
21	VOICE PAIR	FROM TELCO LINE 6	TIP	RED	34	ORANGE-YELLOW	34
	DATA PAIR		RING	YELLOW	35	YELLOW-GREEN	35
	DATA PAIR		A	BLACK	36	GREEN-YELLOW	36
POWER FAIL	TIP	SPARE	TIP	GREEN	37	YELLOW-BROWN	37
	RING		RING	RED	38	BROWN-YELLOW	38
	RING		A	YELLOW	39	YELLOW-SLATE	39
				BLACK	40	SLATE-YELLOW	40
				GREEN	41	VIOLET-BLUE	41
				RED	42	BLUE-VIOLET	42
				YELLOW	43	VIOLET-ORANGE	43
				BLACK	44	ORANGE-VIOLET	44
				GREEN	45	VIOLET-GREEN	45
				RED	46	GREEN-VIOLET	46
				YELLOW	47	VIOLET-BROWN	47
				BLACK	48	BROWN-VIOLET	48
				GREEN	49	VIOLET-SLATE	49
				RED	50	SLATE-VIOLET	50



NOTES  
 (1) TYPICAL CONNECTING BLOCK SHOWN. OTHER TYPES OF STATION DISTRIBUTION CONNECTING BLOCKS ARE AVAILABLE AND MAY BE USED IN LIEU OF THE 66M-XX TYPE  
 (2) ALL STATION CABLE IS TWISTED-PAIR FOUR-WIRE FROM THE 66-XX BLOCK TO THE RJ14 JACK



OPTIONAL NON-KEY SYSTEM STATION WITH A-LEAD CONTROL. (TYPICALLY CAN BE ANY TELEPHONY DEVICE WHICH PROVIDES A LEAD CONTROL)

Figure 4. Model 616 System Interconnection - Typical Connections

Dial Access Public Address (PA) Port

~~Any unused station port~~ can be programmed to be a PA station port instead of a telephone station (see Chapter 4, Section 2 for programming details). When this is done, the audio input of a PA amplifier can be connected to this station connection audio pair as illustrated in Figure 5. The connection must be isolated with a 600 ohm to 600 ohm audio matching transformer. Terminate the audio input of the PA amplifier with a 620 ohm (nominal value) resistor.

- If station 23 is enabled as a PA station, the Common Audible connection points are automatically reconfigured as PA enable terminals. The relay contact closure on these terminals occurs when PA station 23 is dialed. The normal common audible function, as discussed previously, is disabled as long as station 23 is a PA station.
- If station 25 is enabled as a PA station, the Station 17 Audible connection points are automatically reconfigured as PA enable terminals. The relay contact closure on these terminals occurs when PA station 25 is dialed. The normal station 17 audible function, as discussed previously, is disabled as long as station 25 is a PA station.

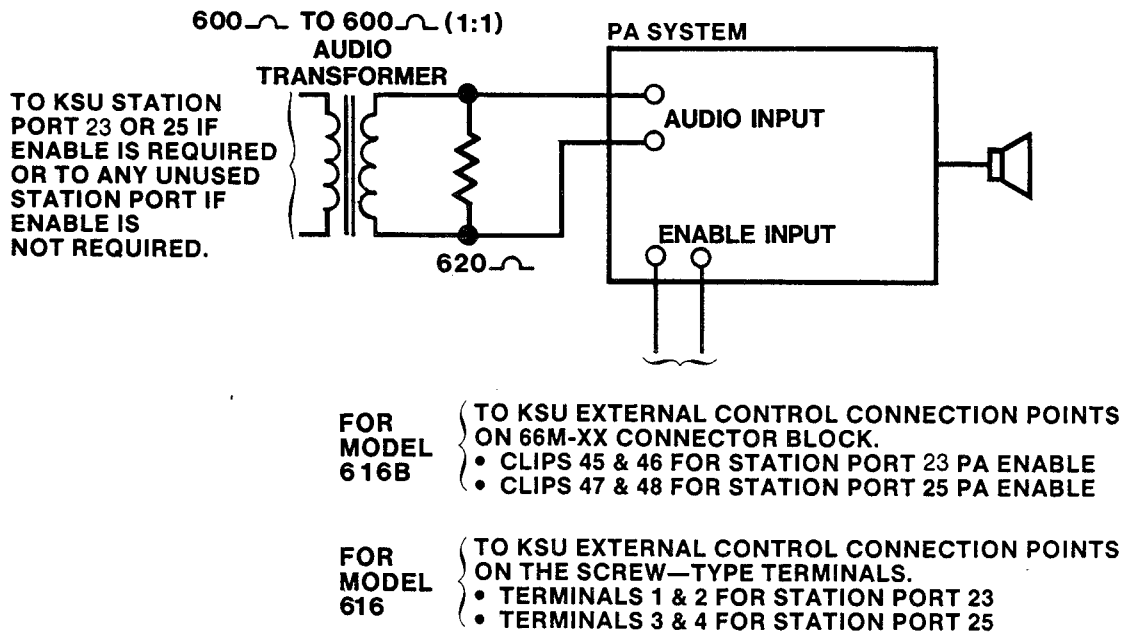

Figure 5. PA Connections

### Auxiliary Line Port (Direct Access Paging Port)

A line port can be configured by Class Of Service (COS) programming (see Chapter 4) to be an AUXILIARY port. As an AUXILIARY port, it can be used to couple a station voice path to an external device. This is done from any allowed station by pressing the proper line select key to select the AUXILIARY port. DTMF tones or dial pulses can be sent through the auxiliary port as needed.

If direct access area paging is to be part of the system, connect the audio input of a paging amplifier to the KSU line jack programmed to be an AUXILIARY port. The input impedance of this port is approximately 600 ohms. The connection must be isolated with a 600-600 ohm audio matching transformer. Terminate the audio input of the paging amplifier with a 620 ohm (nominal value) resistor. A tone select, zone-paging amplifier can be employed if desired. If used, the zone-select code must be dialed after the AUXILIARY port line key is pressed.

### Music On Hold

If music on hold is to be part of the system, connect a KX registered music source to the KSU input jack (phono jack) provided for this purpose. The impedance of this input is approximately 500 ohms. Level adjustment of the music source may be necessary. This may be done during system checkout.

### Busy Lamp Field Stations

An optional station is available which is equipped with a 14 station Busy Lamp Field (BLF). Up to eight BLF stations can be connected to the system. A BLF station can be connected to any odd or even station port in the system per the following guidelines.

- The installed distance between the KSU and the BLF station must be limited to 1000 feet or less.
- The data-line paired station port cannot be used as a BLF station connection or as a regular station connection. Data-line pairing is: 10-11, 12-13, 14-15, 16-17, 18-19, 19-21, 22-24, and 23-25.
- The overload paired station port cannot be used as a BLF station connection but can be used as a regular station connection. Overload pairing is: 10-12, 11-13, 14-16, 15-17, 18-20, 19-21, 22-24, and 23-25.
- A port, paired in either manner with a BLF station, can be used as a PA port if desired.

### DSS/BLF Console

The optional DSS/BLF console may be installed at any station port to work in conjunction with a companion system station connected to the adjacent port (e.g.; port 10 for station and port 11 for console). The installed distance limit between the KSU and the console is the same as that specified for the companion station. Connect all four wires (voice pair and data pair) of the console cable to the station connection block.

The voice pair connections of the console can be used simultaneously to enable a PA port function. Refer to the paragraph in this chapter headed Dial Access Public Address Port, and to the illustration shown in Figure 5. Per that discussion, wire a PA amplifier input to the DSS/BLF console voice-pair at the station connector block clip terminals. Use an audio matching transformer, as discussed in the referenced paragraph and illustration, to provide isolation. If an enable signal is required with the particular PA equipment being used, the console and PA equipment connections are limited to the station ports specified in the above mentioned reference.

The DSS/BLF console port must be programmed as a DSS/BLF port (see Chapter 4 for programming details) before console operation can take place. The console port must be also programmed as a PA port if a PA amplifier has been connected to the voice pair as part of the system.

### CHECKOUT

#### Initial Condition

The system operating features are set to the system default conditions at initial power up. These conditions provide a basic operating system. They can be altered as described in the Chapter 4 Class Of Service programming discussion; however, the system should be initially checked out with the default conditions in place.

The system default conditions are as follows.

- All lines are DTMF
- Voice signalling attempted first when intercom call is made
- 1 sec. pause time
- 2 sec. dial tone recall time
- 30 sec. recall from hold
- All lines private
- All lines are CO lines
- 300 msec. held call abandon time
- No ringing line preference enabled
- No prime line is chosen
- DSS/BLF port is disabled
- PA port is disabled
- No delayed ringing enabled

- No access denied
- No origination denied
- No automatic privacy released
- Day and night ringing patterns set as follows:
  - station 10, 17, and 24 all lines
- System-wide, all call paging in zone D (616B only)
- Printer port set for 110 baud data rate (616B only)
- Line select buttons 1-n selects lines 1-n (squared pairing)

Whenever the system is operating, default conditions can be reset from station 10 per the following instructions.

1. Press the **ITCM** button.
2. Press the following keys: **\*SY** **7PR** **4GH** **6MNO** **\*SY** **#RL** **0OPR** **\*SY**
3. Press the **MONITOR** button.

Check the KSU and telephone installation for proper operation by performing the following actions.

1. Before any AC power is applied to the system, measure the resistance across each station voice and data pair. Disconnect the 25-pair cables from the KSU at the 66M-xx connector blocks but leave the stations connected. Make the measurements from the blocks (refer to Figure 3 to identify the connection points of the voice and data pairs). The measured resistance must be as follows:

VOICE PAIR: 45 OHMS TYPICAL (40 OHMS MIN.--150 OHMS MAX.)  
 DATA PAIR: 45 OHMS TYPICAL (40 OHMS MIN.--150 OHMS MAX.)

Readings which are outside of the above range indicate a possible wiring or station problem.

2. Connect the 25-pair cables, and plug the AC power plug of the KSU into the electrical outlet.



3. Measure the voltage across one voice line and one data line and then across the other voice line and the other data line for each even and odd station. Make the measurements at the 66M-xx blocks (refer to Figure 3 as needed). The measured voltage must be as follows:

UNIT UNDER TEST	66M-xx BLOCK CONNECTION	METER LEAD POLARITY	MEASURED VOLTAGE (+/- 5V)
STATION 10 (Example) Repeat for each even sta.	Voice 1	(+)	+32 VDC
	Data 3	(-)	
	Voice 2	(+)	+32 VDC
	Data 4	(-)	
STATION 11 (Example) Repeat for each odd sta.	Voice 5	(+)	-32 VDC
	Data 7	(-)	
	Voice 6	(+)	-32 VDC
	Data 8	(-)	
Readings other than those shown above indicate a possible wiring or KSU problem.			

4. Check the red light emitting diode (LED) system status indicator. Be sure that it is on steady. If it is off or flashing, disconnect and reconnect the AC power plug. If the indicator is still not on steady, refer to the Failure Analysis Flow Chart found in Chapter 5.
5. Refer to the information provided in Chapter 3 and in the user's instructions supplied with the telephone for operating information.
6. From each telephone station, initiate and receive an outside line and an intercom line call. Be sure to set the ringer volume to the medium or high volume setting at each station.
7. Exercise every feature and option available at each individual station. Be sure that the line select indicators and any other indicators function properly.
8. Once the basic system is verified as completely operational, refer to Chapter 4 and perform the Class Of Service programming.

### CHAPTER 3 SYSTEM OPERATION

#### SECTION 1 DETAILED OPERATING INSTRUCTIONS

This section provides detailed operating procedures for all station features. The illustration shown in Figure 5 points out the operating controls and buttons of the stations. Some features and options illustrated and described herein may not be available on every station in the system.

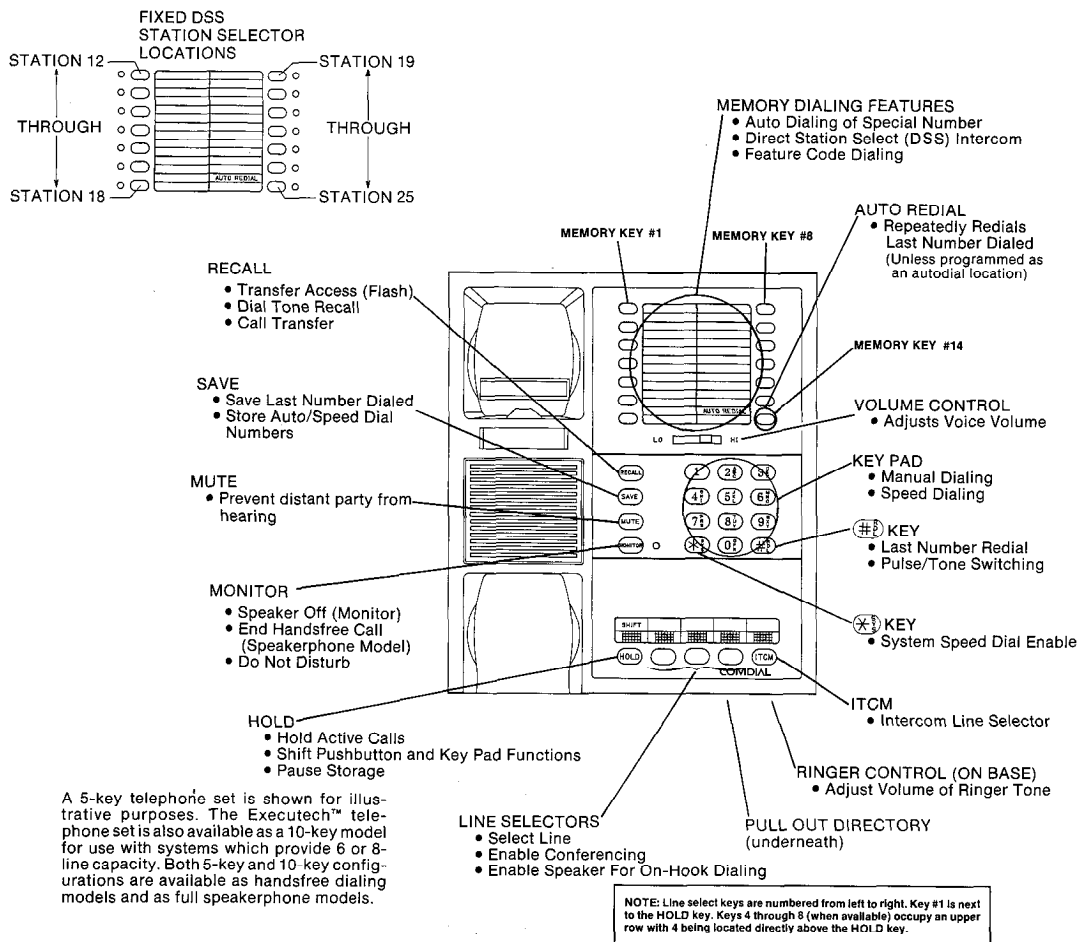

Figure 5. Full Feature Station Controls and Indicators

## BASIC OPERATION

## ORIGINATE A CALL (OUTSIDE LINE)

Press an unlighted line select key. When the dial tone is heard, dial the desired number. The line select indicator will wink slowly at the calling station and be on steady at all other stations when the line select key is pressed. The station speaker will sound the dial tone and the ring back or busy tone signals. If the calling station is not a speakerphone, the user must lift the handset to complete the call when the called party answers. If a busy tone is received or no answer is heard, the user must press the **MONITOR** key to end the call.

## ANSWER A CALL (OUTSIDE LINE)

Press the line select key with the flashing indicator, and lift the handset. The indicator changes from flashing to a wink off at the calling station and to a steady bright at all other stations.

## MANUAL HOLD

Hold A Call (Outside Line)

Ask the outside party to wait, and press the **HOLD** key. The call goes on hold and the indicator changes to winking at all stations. As soon the **SHIFT** **HOLD** key is pressed, the user can hang up or use any available telephone function. To return to the held party, press the line select key. Refer to the paragraph headed CALL TRANSFER for a discussion on transferring a held call.

Automatic Abandoned Hold Release

If a held party hangs up, the key system will: wait a programmed period of time, automatically return the holding station to an idle condition, and turn off the line select indicator. This feature is contingent upon the availability of a loop disconnect feature in the TELCO/PBX equipment.

Timed Hold Recall

If the key system is so programmed, the line select indicator will flutter rapidly at all stations and three quick tones bursts will sound at the holding station when someone has been on hold beyond a predetermined time. The holding station will periodically sound the three quick tone bursts as long as the call remains on hold.

Exclusive Hold

If the **SHIFT** **HOLD** key is pressed twice and no other stations are connected to the same line, an exclusive hold condition is

activated. The line select indicator will be on steady at all other stations and will wink off at the calling station. An exclusive hold will prevent any other station from accessing the held line. Should a recall from hold occur, the exclusive hold condition will revert to a standard hold condition allowing any other station to access the line.

#### INTERCOM CALLING

##### Originating A Tone Signalled Intercom Call

1. Press the ITCM key. The intercom dial tone will sound, and the intercom indicator of the calling station will wink slowly.
2. Dial the intercom number of the desired station. If the handset is off-hook, press the **ITCM** key again. This action places the called station in a tone signalling mode. A double ringing tone burst, repeated every 4 seconds, will be heard at the station being called. Two bursts of a ring back tone will be heard at your station every 4 seconds.
3. If handset on the calling station is on-hook when the called party answers, it must be lifted to complete the conversation link.
4. If the called station is busy on another intercom call, the system will return a busy tone. If the called station is busy on an outside call, the system will return a fast ring back tone. The caller may wait for the called party to answer or disconnect by pressing the **MONITOR** key.

##### Answering A Tone Signalled Intercom Call

When the ringing tone sounds, the user must lift the handset to answer the call. If currently engaged in a call on an outside line, the user may disconnect from it by pressing the hookswitch, or place it on hold by pressing the **ITCM** key when the flashing intercom indicator is observed.

##### Originating A Voice Signalled Intercom Call

1. Lift the handset (even when using a speakerphone), press the **ITCM** key, and listen for the dial tone. Dial the intercom number of the desired station.
2. The calling station will sound a single tone burst to let the user know that the voice signalling mode is active. They can speak their message after hearing this confirming tone.
3. If the called station is busy on an outside call, the system will revert to a tone signalling mode and the calling station will receive a fast ring back tone.

4. If the called station is busy on an intercom call, the calling station receive a busy tone.

#### Answering A Voice Signalled Intercom Call

A user can respond to a single tone burst followed by a caller's voice without lifting the handset. They need only to speak toward the telephone in a normal tone of voice. A two way conversation may continue in this handsfree manner or the user can lift the handset for a private conversation.

#### CALL TRANSFER

##### Common Line Pickup

If the incoming line is common to the calling station and to the station to which a transfer is to be made, a common line pick up transfer can be effected by the station user. To do so, proceed as follows:

1. While the call is active, press the **ITCM** key. This action automatically places the call on hold.
2. Make an intercom call to the station to which a transfer is desired, announce the call, identify the line, and hang up.
3. That station user must press the line select key of the called station to pick up the call.

##### System Transfer

If the called station does not have direct access to the active line to receive a transferred call, follow the procedure detailed below to transfer a call.

1. While the call is active, press the **ITCM** key. This action automatically places the call on hold. Use the intercom to contact the station to which the transfer is directed.
2. The user of the called station must lift the handset to accept a transferred call. Once the called station is ready to receive the call, the caller must press the **RECALL** key on the calling station. The transfer will take place.
3. If the called station does not answer, the caller can press the **RECALL** key on the calling station to return to the held party. If the called party declines the call, they must hang up. The caller can then press the **RECALL** key to return to the held party.

#### MULTILINE CONFERENCING

The key system will allow one telephone set to access two outside lines at the same time. The resulting three-way conversation is

referred to as multiline conferencing. When using this conferencing feature, it should be noted that under certain line conditions transmission levels may not be adequate. To enable multiline conferencing, the station user must perform the following procedure.

1. Answer or make a call, and place it on hold.
2. Select an idle line, and make a second call.
3. Establish the conference per the following steps:
  - a. Press and hold the line select key of the second call.
  - b. Press the line select key of the first call.
  - c. Release both line select keys.

Both lines are now connected to the same station in a conference call.

4. The user can selectively disconnect one member of the conference call while saving the other by pressing the line select key of the line to be saved. The other line will automatically be disconnected.
5. The user may hold conferenced lines and use other telephone features. The conference call can be re-established per step 3, above.
6. Other stations may be added to the conference call by placing the conferenced line on hold and then releasing privacy. Refer to the paragraph titled ADD-ON CONFERENCING/PRIVACY RELEASE for details.
7. End the conference call by hanging up.

#### AUTOMATIC PRIVACY

A station can be programmed to operate in a normally private or a non-private mode. This feature can be programmed on a per line basis. The system manager determines station features.

The private mode, when programmed, allows exclusive use of an active line. No other station can connect to an active line unless the add-on conferencing feature described below is used.

In the non-private mode, when it is programmed, several stations in the system can connect to a line at one time. When a station is connected to a line, other stations can also connect to it. Another station user may connect to a line by pressing the line select key on their station. The resulting conference is referred to as common line pick up.

## ADD-ON CONFERENCE/PRIVACY RELEASE

Once a station connects to a line in a private mode, all other stations are excluded from connecting to it. A user can add other stations to that line as follows:

1. Place the call on hold, and use the intercom feature to invite an additional station to join the line.
2. Press and hold the line select key on the first station. This makes the line non-secure. The user of the second station must press the same line select key to join the line.
3. Release the line select key after the other station has joined the conversation to return the line to a private condition for both stations.

## FEATURES OPERATION

## LAST NUMBER REDIAL

A station is equipped with a last number redial feature, it may be used to repeat the last number manually dialed from the dial pad. A station user may employ the feature as follows:

1. Press the  $\text{\#}^{\text{R}}_{\text{P}}$  key. The station will automatically turn on the monitor speaker, select the station prime line, if available, or the last active line, and will dial the last number (up to 31 digits) that was dialed from the keypad.

## NOTE

The keypad always exists, at idle, as an automatic line select speed dialer. If a line select key is pressed to select a line, the station converts the keypad to a manual dialing mode. Therefore, to avoid the need to manually dial a number after manually selecting a line, the user must convert the keypad back into a speed dialer by pressing the  $\text{SHIFT}$  key.

2. Listen for an answer or a busy tone. Pick up the handset to complete an answered call. Press the  $\text{HOLD}$  key to terminate a busy or unanswered call. Press the  $\text{MONITOR}$  key to

## SAVED NUMBER REDIAL

The  $\text{SAVE}$  key can be used to store the last number manually dialed from the keypad. After the number is dialed and before any other numbers are dialed, the user can press the  $\text{SAVE}$  key to cause the last manually dialed number to be stored for later recall. This number remains stored until replaced by another one. This action can be taken while the station is either on-hook or off-hook. To dial using the saved last number feature, the user must do as follows:

1. Press the <sup>SHIFT</sup> **(HOLD)** key and immediately press the **(SAVE)** key. The station will automatically turn on the monitor speaker; select the station prime line, if available, or the last active line; and dial the saved number.
2. Listen for an answer or a busy tone. Pick up the handset to complete an answered call. Press the **(MONITOR)** key to terminate a busy or unanswered call.

#### AUTOMATIC REDIAL (OF BUSY NUMBERS)

An automatic redial of a busy number can be performed by a station user. This feature is available when the station is connected to a line and a dialing operation has taken place resulting in a busy signal or no answer. Automatic redial is automatically disabled whenever a memory dialing feature is programmed at memory key 14 but is automatically restored when the programmed feature is cleared.

To use the automatic redial feature, proceed as follows:

1. When the busy number signal is heard, press the memory key 14 (AUTO REDIAL). Hang up the handset if off hook. The **(ITCM)** light will flash rapidly to indicate that automatic redial is active.
2. After a 1 minute wait, the system will activate the station monitor speaker, reselect the line, and redial the number. If the handset is not picked up or the **(MONITOR)** key is not pressed (because of a continued busy signal), the line will be dropped approximately 20 seconds after the number is completely dialed. Automatic redial action will repeat ten times. If the ringing tone is heard, the handset must be picked up or the **(MONITOR)** key pressed to take control of the call. The indicator will stop flashing when this action is taken.

#### NOTE

On a speakerphone, take control of a call either by pressing the **(MONITOR)** key or by lifting the handset.

Although a conversation can be established on a speakerphone without taking control of the call, the line will be disconnected within 20 seconds if control action is not taken.

3. Cancel the automatic redial by lifting and replacing the handset. Any other use of the station while the automatic redial feature is active will cancel further automatic redial action. The indicator will stop flashing when automatic redial is cancelled.



## AUTOMATIC AND SPEED DIALING (STATION)

A station is equipped for both automatic dialing and speed dialing. These features provide methods by which numbers can be retained for easy retrieval. Up to fourteen 15-digit numbers in the automatic dial portion and up to ten 15-digit numbers in the speed dial portion can be stored for retrieval. An additional ten 31-digit numbers can be stored at station 10 and used by all stations for system-wide speed dialing. In the following paragraphs, the method of storing numbers for use is the same for all types of dialing modes and is described together; however, the way that these features are used is somewhat different and is described separately.

Storing An Auto Dial Or A Speed Dial Number

A user may store a desired number as follows:

1. Press the **ITCM** key, and listen for the dial tone.
2. Press the **SAVE** key. The intercom dial tone will stop.
3. Press a memory key for the automatic dial number to be stored or press a keypad key (1-0) for the location code of the speed dial number to be stored. A tone burst will sound to confirm this action.
4. If a specific line or intercom is to be stored as part of the number, press the line select or intercom key corresponding to it. A tone burst will confirm this selection. This action is optional. If a specific line or intercom is not stored, the system will automatically select the prime line (if available) or the last line used to originate a call when automatically dialing the number.
5. Dial the number sequence as if it were being dialed on-line. A pause can be stored by pressing the **SHIFT** key, and a hookswitch flash can be stored by pressing the **HOLD** key. Up to 15 digits including the numbers, #'s, \*'s, pauses, and flashes can be stored at each location.
6. Repeat steps 2 through 5 for each desired automatic dial number or speed dial number. If the memory key 14 is programmed as an automatic dial location, the automatic redial feature normally controlled by this key is disabled. To restore the automatic redial feature, repeat steps 1 and 2, press key 14.
7. Press the **MONITOR** key to end the procedure.

Automatic Dial Operation

1. Press a memory key. A station will automatically turn on the monitor speaker; select a line (programmed as part of the number, the station prime line, or the last active line); and dial the number.
2. Listen for an answer or a busy tone. Pick up the handset to complete an answered call. Press the **MONITOR** key to terminate a busy or unanswered call.

Speed Dial Operation

1. Press the keypad key corresponding to the desired number. A station will automatically turn on the monitor speaker; select a line (stored as part of the number, the station prime line, or the last active line); and dial the number.

## NOTE

The keypad always exists, at idle, as an automatic line select speed dialer. If a line select key is pressed to select a line, the station converts the keypad to a manual dialing mode. Therefore, to avoid the need to manually dial a number after manually selecting a line, the user must convert the keypad back into a speed dialer by pressing the **SHIFT HOLD** key.

2. Listen for an answer or a busy tone. Pick up the handset to complete an answered call. Press the **MONITOR** key to terminate a busy or unanswered call.

## SPEED DIALING (SYSTEM)

The system can have speed dial numbers stored which can be accessed by any station in the system. The system manager determines what numbers are available with this feature. The user can employ this feature per the following procedure.

1. Press the **X<sup>S</sup><sub>S</sub>** key on the keypad and immediately press the keypad key corresponding to the desired number. A station will automatically turn on the monitor speaker; select a line (stored as part of the number, the station prime line, or the last active line); and dial the number.

## NOTE

The keypad always exists, at idle, as an automatic line select speed dialer. If a line select key is pressed to select a line, the station converts the keypad to a manual dialing mode. Therefore, to avoid the need to manually dial a number after manually selecting a line, the user must convert the keypad back into a speed dialer by pressing the **SHIFT HOLD** key.

2. Listen for an answer or a busy tone. Pick up the handset to complete an answered call. Press the **MONITOR** key to terminate a busy or unanswered call.

### System Speed Dial Number Storage (Station 10 Only)

The system speed dial numbers can only be stored from station 10. These numbers can be up to 31 digits in length. The station 10 user can program these numbers per the following instructions:

1. Press the **ITCM** key and listen for the dial tone.
2. Press the **X** key on the keypad. Note that the dial tone stops.
3. Press the **SAVE** key. A tone will sound to confirm the mode entry.
4. Press a keypad key (1-0) to establish the location code of the first number to be stored. A tone will sound to confirm this action.
5. If a specific line or the intercom is to be stored as part of the number, press the line select key for that line. A tone will sound to confirm this action.
6. Dial the number sequence from the keypad. Press the **SHIFT** **HOLD** key to store a pause if needed, and press the **RECALL** key to store a flash signal if required. Up to 31 digits (numbers, #'s, \*'s, pauses, and flashes) can be stored in this manner.
7. Repeat steps 3 through 6 for each desired speed dial number.
8. Press the **MONITOR** key to end the procedure.

### ON-HOOK DIALING/LINE MONITOR

The station is essentially a handsfree station which allows on-hook dialing and call establishment. A user only needs the handset for originating intercom calls and to complete a voice link after a call is established. During a conversation a user may switch from the handset to the call monitor speaker and back again.

After a handsfree call is established, the user must lift the handset from the cradle to provide a voice link. The monitor indicator light will turn off. The handsfree operation can be reactivated for monitoring purposes by pressing the **MONITOR** key and replacing the handset in the cradle. The indicator will turn on once more when this action is taken. To hang up when the call is finished, press the **MONITOR** key again. Note that the indicator light turns off once more.

## DIAL TONE RECALL/FLASH OPERATION

### Dial Tone Recall

It is sometimes convenient to have a line disconnect key to use when making one call right after another. When custom calling features are not available from the host system, the key system can be programmed to allow the **RECALL** key to act as a positive disconnect key.

Dial tone recall and flash operation are mutually exclusive. The system will be programmed to provide only one of these features.

### Flash Operation

When custom calling features are available from the host system, the instructions for accessing them indicate that the user should first execute a "flash" operation. Each station is equipped with a RECALL key which can be pressed to cause a precisely timed flash signal to be electronically generated.

Flash operation and dial tone recall are mutually exclusive. The system will be programmed to provide only one of these features.

## AREA PAGING INTERFACE

If the telephone system includes the proper external paging equipment, and a station is programmed to enable paging, it can be used to voice address an area of the site in order to find, notify, or summon someone. A user can access this paging feature directly by pressing the proper line select key and speaking into the handset. If zone paging is available, dial the proper zone code before speaking. Paging access may require the use of the intercom and the dialing of a 2-digit code. The system manager can provide complete details.

## ALL-CALL AND ZONE PAGING - VIA STATION SPEAKERS (MODEL 616B)

All Call And Zone Paging uses the station monitor speaker and handset to receive and originate one-way messages. Such messages could be used to find, notify, or summon someone. With this feature, a station may be programmed to only receive a message; however, it may be programmed to originate a message as well. Also, a station may be a part of only one call zone, a part of several call zones, or a part of the system-wide all call. The system manager determines the capabilities of the stations. Reception of all call and zone paging messages are automatic. If a station has message originating capability, it can be used to announce messages to other stations in the system as follows:

1. Determine to which zone the message is directed.

2. Lift the handset, press the **(ITCM)** key, and then press the keypad key which corresponds to the zone to be called.

Key **(4<sup>GHI</sup>)** selects zone A

Key **(5<sup>JKL</sup>)** selects zone B

Key **(6<sup>MNO</sup>)** selects zone C

Key **(7<sup>PRS</sup>)** selects system-wide all call (Unless your telephone system is programmed to provide a zone D instead)

3. Announce the message, and hang up the handset.

**HINT:** Store the calling sequence ( **(ITCM)** KEY ) at a memory key location, and use the automatic dial feature to provide one-key access to the all call and zone paging feature.

#### DIRECT STATION SELECT (DSS) INTERCOM

##### Fixed DSS

The system has a Fixed DSS feature built into it. The feature allows a user to make a voice signalled intercom call to certain stations without having to first store the numbers. With a Model 616 system, stations 12 through 25 can be called using memory keys 1 through 14.

To use Fixed DSS, the user must press the **(ITCM)** key, and then press a memory key. (The station key locations begin with the top left location, proceed down that column, and continues with the top of the right column.) Any currently active call is automatically placed on hold, and an intercom call is placed to the selected station. The type of signalling first attempted is dependent upon COS programming but the handset must be lifted to enable voice signalling (even with a speakerphone). Otherwise, tone signalling is enabled.

##### Programmed DSS

When a user is required to answer and announce a high volume of calls, Programmed DSS may be advantageous because a selection need not be prefixed by pressing the **(ITCM)** key. Store an intercom

line selection action and a station number at those memory key locations to be used for DSS. (Refer to the paragraph headed STORING AN AUTO DIAL OR A SPEED DIAL NUMBER for number storing instructions.)

To use Programmed DSS, simply press a DSS memory key. Any currently active outside call will be automatically placed on hold, and an intercom call will be placed. The type of signalling first attempted is dependent upon COS programming but the handset must be lifted to enable a voice signalling (even with a speakerphone). Otherwise, tone signalling is enabled.

## NIGHT TRANSFER (Station 10 Only)

The night transfer mode can only be set from station 10. No other station in the system can control this feature. This operating mode is programmed to automatically transfer the ringing of all incoming calls to a particular station or stations for off-hour or special purpose answering. The station 10 user can set this mode as follows:

1. Press the **ITCM** key, and listen for the dial tone.
2. Press the **#<sup>R</sup><sub>L</sub>** key on the keypad. Note that the dial tone stops and the intercom indicator will flash rapidly.

To deactivate the night transfer mode, repeat steps 1 and 2. The intercom indicator will turn off.

## DO NOT DISTURB

The user can disable the station ringer by pressing the **MONITOR** key once. The indicator will remain on steady as a reminder that this feature is active. To re-enable the ringer, the user must press the **MONITOR** key again. This feature can be activated with the handset on or off hook.

## MUTE

During a conversation, a user may press and hold the **MUTE** key to prevent the distant party from hearing. Releasing the **MUTE** key allows a two-way conversation to resume.

## PULSE/TONE DIAL SWITCHABLE

The method of dial signalling used is determined by system programming. If the line has been configured to allow pulse dialing, the initial dialing mode will be pulse. Pulse dialing will remain active during a dialing operation until tone dialing is selected by pressing the **#<sup>R</sup><sub>L</sub>** key. Once selected, the tone dialing mode will remain active until the station is disconnected from the line (hang up occurs). After tone dialing has been selected, the **#<sup>R</sup><sub>L</sub>** key will generate a DTMF tone when pressed again. The **#<sup>R</sup><sub>L</sub>** key can be pressed during the storing of a memory dialing sequence to cause the pulse/tone switching to occur during the automatic dialing of a number.

## LINE PRESELECTION (PRIME LINE)

The system programming can assign a particular line to a station as a principle or "prime" line. If a station has been assigned a prime line, this line is automatically selected by the station for each call originate action unless it is already busy. Also when a call comes in on the prime line, the user can answer it by

lifting the handset without pressing the line select key. If a station does not have an assigned prime line, the user must manually select a line before making or receiving a call.

#### RINGING LINE PREFERENCE

The system programming can be performed to enable a ringing line preference feature at a station. If enabled, an audibly ringing line (either outside or intercom) will be automatically answered when the station handset is lifted or the **MONITOR** key is pressed on a speakerphone. Neither the line select key nor the **ITCM** key will have to be pressed to connect to the ringing line.

#### DIALING 0 FOR ATTENDANT

When a user presses the **ITCM** key and then presses the 0 key, an intercom call is automatically made to station 10. This feature allows a station user to call the system attendant using a familiar method (i.e.: dialing 0 for the operator).

### OPTIONAL FEATURES OPERATION

#### SPEAKERPHONE OPERATION

##### Originating A Call

To originate a speakerphone call, the user must select an idle line and dial the desired number. When the called party answers a handsfree conversation can begin. The user must press the **MONITOR** key to end the call.

##### Answering A Call

To answer a speakerphone call, the user must press the line select key of the ringing line and speak in a normal tone of voice toward the station. The audio volume level is adjustable with the volume control that is located on the faceplate. The user must press the **MONITOR** key to end the call.

##### Switching Operation Between Handset And Speakerphone

During a conversation a user may switch from handset operation to speakerphone operation and back again as follows:

##### Handset To Speakerphone

1. Press the **MONITOR** key (note that the indicator turns on), and return the handset to the cradle.
2. Continue the conversation in a handsfree mode using the speakerphone.
3. Hang up when the call is finished by pressing the **MONITOR** key again (note that the indicator turns off).

Speakerphone To Handset

1. During a speakerphone call, lift the handset (note that the indicator light will turn off).
2. Continue the conversation in a private mode using the handset.
3. Reactivate the speakerphone operation by pressing the **MONITOR** key and hanging up the handset (note that the indicator light will turn on once more).
4. Press the **MONITOR** key again to end the call.

BUSY LAMP FIELD STATION OPERATION

An optionally available 8-line telephone station is equipped with 14 visual indicators adjacent to the memory keys. This station provides all of the available system features in addition to a Busy Lamp Field (BLF) display. It is normally connected as the attendant's station.

The BLF indicators always display the status of the stations which are reached via the Fixed DSS feature built into the station. No DSS programming is required to activate the BLF indicators.

BLF STATUS

The BLF indicators display the following station status when in use:

LIGHT OFF	Station idle - can be signalled
LIGHT FLASHING	Station busy on intercom line - cannot be signalled.
LIGHT ON STEADY	Station busy on outside line - receives subdued ringing and the intercom line indicator flashes.
	Station in do not disturb mode - receives no ringing but intercom line indicator flashes.



## STATION OPERATING CONDITIONS

## VOLUME CONTROL (RINGER)

A station user can adjust the loudness of the tone ringer at a station. The control for doing this is located on the bottom of the telephone set. Adjust the lever control toward the center of the telephone housing to increase the loudness and toward the edge of the telephone housing to decrease the loudness.

## DISTINCTIVE RINGING (RINGING PATTERNS)

There are four distinctive ringing patterns in the system. They are described below.

1. TELCO/PBX Ring: The ring pattern provided by the host system.
2. Intercom Tone Signalling: The tone signalling ring pattern is two tone bursts sounded every four seconds.
3. Intercom Voice Signalling: A voice signalling ring pattern is two tone bursts sounded once.
4. Timed Hold Recall: The timed hold recall ring pattern is three tone bursts sounded at the end of each recall period at the station that put the call on hold.

## INTERCOM CALL PROGRESS TONES

There are five intercom tone patterns as follows:

1. Intercom Dial Tone: The intercom dial tone is a continuous tone.
2. Intercom Ring Back: The intercom ring back tone is two tone bursts sounded every 4 seconds
3. Intercom Fast Ring Back: When a called station is busy on an outside call, two tone bursts sounded every second is received at the calling station. These tone bursts also signify that the called station cannot be voice signalled.
4. Voice Signalling Ring Back: When voice signalling is activated, a single tone burst will sound to indicate that the caller should proceed with the voice announcement.
5. Intercom Busy Tone: One tone burst is sounded every second when a called station is busy on an intercom call or does not exist.

CLASS OF SERVICE AND SPEED/AUTOMATIC DIALING CONFIRMATION TONES

When the Class Of Service (COS) programming or speed/automatic dial programming is performed, there are several different tone signals used for program confirmation. They are as follows:

1. COS Base Level Mode: A continuous tone sounds to indicate that the base level programming mode is active.
2. Invalid COS Entry: An invalid or improper program entry is signalled by one occurrence of three bursts of a tone.
3. Entry Accepted: A valid or correct program entry is signalled by one tone burst.
4. Accepting Dialing Digits: When dialing digits are being programmed for later recall by the speed and automatic dialer, one tone burst is sounded as each keypad key is pressed.

VISUAL INDICATIONS

The LINE SELECT, ITCM and MONITOR indicators on the station indicate the status of a particular line or feature. The possible indications are described below.

INDICATOR	CALL STATUS	INDICATION
LINE SELECT	Idle In use-your station On hold-your station On hold-other station Exclusive hold-your station Exclusive hold-other sta. Busy line Ringing Recall (held call timeout)	Dark On with short wink off every 2 sec. Fast flash with wink off every 2 sec. Fast flashing On with long wink off every 2 sec. On steady On steady Flashing Flutter with wink off every 2 sec.
INTERCOM	Ringing In use-your station All intercom channels busy Auto redial active Night mode	Flashing On with short wink off every 2 sec. On steady Fast flashing Fluttering (Station 10 only)
MONITOR	On line and speaker on (microphone also on if speakerphone) Do not disturb mode	On steady  On-steady

SECTION 2  
CLASS OF SERVICE PRINTOUT

When a data printer is connected to the printer port, it can be commanded to print the class of service (COS) programming configuration for the system, lines, and stations. Partial or complete printouts can be obtained.

Use the following procedure to obtain the COS printout.

1. At Station 10, place the system in the base level program entry mode.
  - a. Press the **(ITCM)** key.
  - b. Once the dial tone is heard, press the **(X<sup>S</sup><sub>S</sub>)** key on the keypad.
  - c. Press, in sequence, the **(7<sup>P</sup><sub>R</sub><sup>S</sup>)**, the **(4<sup>G</sup><sub>H</sub><sup>S</sup>)**, and the **(6<sup>M</sup><sub>N</sub><sup>O</sup>)**, keypad keys. A tone burst will sound to indicate that the base level programming mode is entered.
  - d. Press the **(X<sup>S</sup><sub>S</sub>)** key and listen for dial tone.
2. Press a memory key to select the type of printout desired per the following chart.

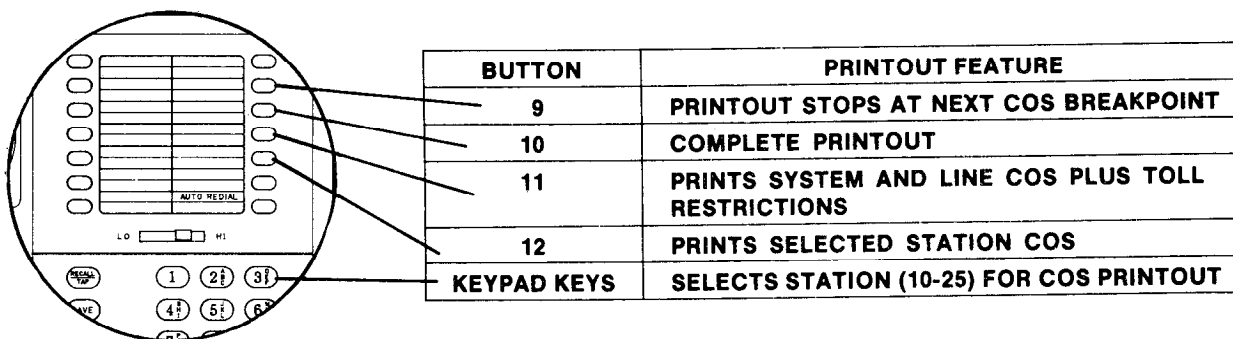

3. When a particular station COS printout is desired, follow the memory dialing feature key operation by pressing keypad keys which correspond to the desired station (e.g., press keys **(1)** and **(2<sup>A</sup><sub>B</sub><sup>C</sup>)** to select station 12).
4. COS printout will begin immediately. Press the **(MONITOR)** key to exit the base level program entry mode.

Typical COS printouts are shown on the following page.

```

SYSTEM COS

  PAUSE  1.0 SEC
  PULSE 10 PPS
  FLASH 1960 MSEC
  THR   30 SEC
    
```

```

LINE COS

LINE PRV  TYPE  PU-  HOLD  TOLL
   RLS                LSE 50MS TABLES

  1      C.O.           123
  2      C.O.           1234
  3      C.O.           1234
  4      C.O.    X
  5      C.O.
  6      AUX
    
```

```

TOLL TABLES

TABLE 1  DENY      TABLE 5  DENY
1  31804           1
2  1212            2
3  1312            3
4  1414            4

TABLE 2  ALLOW     TABLE 6  DENY
1  18049782200    1
2  13125552345    2
3  12125551212    3
4                      4

TABLE 3  DENY      TABLE 7  DENY
1  3?7            1
2  757            2
3  28?            3
4                      4

TABLE 4  ALLOW     TABLE 8  DENY
1                      1
2                      2
3                      3
4                      4
    
```

```

STATION 10

TOLL RES.
P.A.
PRIME LINE  -

LINE          1 2 3 4 5 6

RING          X X X X -
DELAY RING                X X
NITE RING       X X X X X X
ACCESS DENY
ORIGIN DENY
PRIVACY RLS

ALL CALL      RECEIVE  ORIGIN
GROUP         A B C D  A B C D
              X X X X  X X X X

BUTTON        1 2 3 4 5 6 7 8
LINE NO.      1 2 3 4 5 6
    
```

```

STATION 18

TOLL RES.123
P.A.
PRIME LINE  2

LINE          1 2 3 4 5 6

RING          X
DELAY RING     X
NITE RING                X X
ACCESS DENY
ORIGIN DENY
PRIVACY RLS

ALL CALL      RECEIVE  ORIGIN
GROUP         A B C D  A B C D
              X X X X  X X X X

BUTTON        1 2 3 4 5 6 7 8
LINE NO.      1 2 3 4 5 6
    
```

Figure 6. Typical COS Printouts

## CHAPTER 4 SYSTEM PROGRAMMING

### GENERAL INFORMATION

- Class Of Service (COS) programming consists of setting the Class Of Service (COS) operating conditions. COS programming is divided into the following three major categories: General System COS, Line COS, and Station COS.
- All COS programming commands must originate at station 10. No COS programming commands can be accepted from any other station connected to the system. COS programming causes station 10 to default to a square condition (line select key 1 selects line 1, key 2 selects line 2, etc.). It is recommended that station 10 always remain in a square condition to avoid possible programming confusion.
- COS programming does not require that a sequential process be followed once the base level program entry mode has been established except where noted herein.
- The system defaults to preset characteristics when it is initially powered up or whenever programmed to do so. If the default characteristics, or any other previously set characteristics, are satisfactory, those portions of the programming sequence may be omitted.
- Prior to taking any programming action, record the system, line and station COS conditions on Table 2a, 2b, and 2c (included at the end of this chapter). Also, record all toll restriction requirements on Table 2d.
- THE PROGRAMMING STEPS MUST BE PERFORMED WITH LESS THAN 17 SECONDS OF DELAY TIME BETWEEN KEYSTROKE OPERATIONS. A delay of longer than 17 seconds causes the KSU programming mode to time out.

### BASE LEVEL PROGRAM ENTRY MODE

The first step in a COS programming sequence is to enter the base level programming mode. Once in this mode, COS can be set as desired.

1. Press the **ITCM** key. The dial tone will sound.
2. Press the following keys in sequence: **\*SY** **7PRS** **4GH** **6MNO**  
Note that the dial tone stops and a tone burst sounds to indicate that the base level programming mode is entered.
3. Press the **\*SY** key. The dial tone will return as a confirmation that the base level mode is active.
5. Proceed from this point to program the COS.

## SYSTEM COS

The System COS programming sets the following system characteristics:

- DTMF or pulse tone dialing
- System default conditions
- Type of signalling first attempted during an intercom call
- Time interval for a programmed pause used with auto/speed dial
- Parameters for pulse dialing
- Hookswitch flash time/dial tone recall interval
- Time out time interval for hold recall
- Toll restriction table entries

1. Perform the base level program entry procedure:

Press the following keys ITCM \*<sup>S</sup>/<sub>S</sub> 7<sup>P</sup>/<sub>RS</sub> 4<sup>G</sup>/<sub>HL</sub> 6<sup>M</sup>/<sub>NO</sub> \*<sup>S</sup>/<sub>S</sub>  
 A dial tone will sound.

2. Select the PULSE/TONE or TONE ONLY dialing system default characteristics.

- a. Press the #<sup>B</sup>/<sub>L</sub> key on the keypad. The dial tone will stop to confirm the selection.
- b. Press the 0<sup>O</sup>/<sub>R</sub> key to select the TONE ONLY dialing condition or press the 1 key to select the PULSE/TONE dialing condition. A tone burst will sound to confirm the selection.
- c. Press the \*<sup>S</sup>/<sub>S</sub> key on the keypad. The dial tone will return.

In addition to setting the dialing mode, the above action causes the system to default to a fixed set of operating conditions as follows:

- All lines either DTMF or Pulse/Tone switchable (per step 2b.)
- Voice signalling attempted first when intercom call is made
- 1 sec. pause time
- 2 sec. dial tone recall time
- 30 sec. recall from hold
- All lines private
- All lines are CO lines
- No toll restriction set
- 300 msec. held call abandon time
- No ringing line preference enabled
- No prime line is chosen
- DSS/BLF port is disabled
- PA port is disabled
- No delayed ringing enabled
- No access denied
- No origination denied
- No automatic privacy released
- Day and night ringing patterns set as follows:
  - station 10, 17, and 24 all lines
- System-wide, all call paging in zone D (model 616B only)
- Printer port set for 110 baud data rate (model 616B only)
- Line select keys 1-n selects lines 1-n (squared pairing)

3. Select the type of intercom signalling that is first performed when an intercom call is placed.

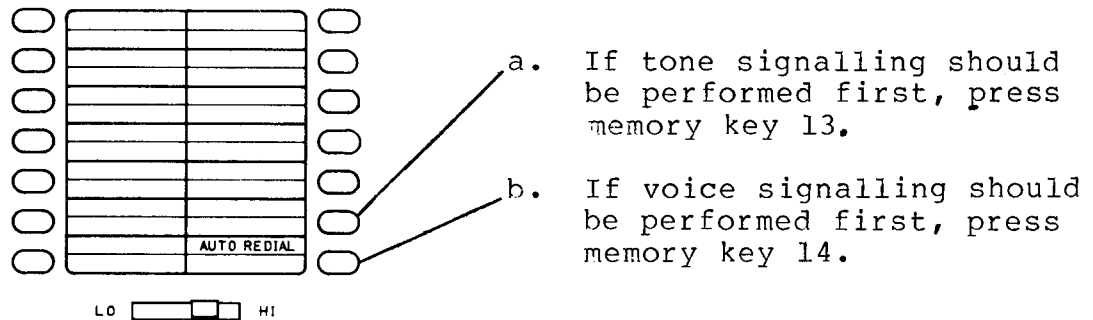

c. Press the  key on the key pad.

4. Select the time interval for a programmed pause .
  - a. Press the **(4<sup>G</sup><sub>H</sub>)** key on the keypad. The dial tone will stop.
  - b. Press a key on the keypad to select a time interval from the following chart. A tone burst will sound to confirm to selection.

<u>KEY</u>	<u>TIME (SECONDS)</u>	<u>KEY</u>	<u>TIME (SECONDS)</u>
1	.5	6	5.0
2	1.0 (DEFAULT)	7	7.5
3	1.5	8	10.0
4	2.0	9	15.0
5	3.0	0	20.0

5. Press the **(X<sup>S</sup><sub>S</sub>)** key. The dial tone will sound.
6. Select the pulse dial operating characteristics.
  - a. Press the **(5<sup>J</sup><sub>K</sub>)** key on the keypad. The dial tone will stop.
  - b. Press a key on the keypad to select an operating characteristic per the following chart. A tone burst will sound to confirm the selection.

<u>KEY</u>	<u>PULSES PER SECOND</u>	<u>BREAK/MAKE RATIO</u>
1	10 PPS	60/40
2	20 PPS	60/40

7. Press the **(X<sup>S</sup><sub>S</sub>)** key on the keypad. The dial tone will sound.



8. Select the flash operation/dial tone recall time interval.

- a. Press the  $\textcircled{6^M}$  key on the keypad. The dial tone will stop.
- b. Press a key on the keypad to select a time interval per the following chart. A tone burst will sound to confirm the selection.

KEY	TIME INTERVAL
1	80 MSEC.
2	300 MSEC.
3	500 MSEC.
4	600 MSEC.
5	750 MSEC.

KEY	TIME INTERVAL
6	875 MSEC.
7	1.0 SEC.
8	1.5 SEC.
9	2.0 SEC. (DEFAULT)
0	3.0 SEC.

9. Press the  $\textcircled{X^S}$  key on the keypad. The dial tone will sound.

10. Select the hold recall time interval.

- a. Press the  $\textcircled{7^R}$  key on the keypad. The dial tone will stop.
- b. Press a key on the keypad to select a time interval from the following chart. A tone burst will sound to confirm the selection.

KEY	HOLD RECALL TIME
1	30 SEC. (DEFAULT)
2	60 SEC.
3	90 SEC.
4	120 SEC.
5	180 SEC.

KEY	HOLD RECALL TIME
6	240 SEC.
7	300 SEC.
8	360 SEC.
9	420 SEC.
0	DISABLED

NOTE

It is suggested that the 0 program selection (Hold Recall Time Disabled) not be made. Setting this value makes it possible for an exclusive hold condition, when set at a station, to place a line on a permanent hold that cannot be released at any other station.

11. Press the  $\textcircled{X^S}$  key on the keypad. The dial tone will sound.

12. Select the toll restriction table entries (model 616B only). Refer to the programming table (Table 2d) found at the end of the chapter to preselect the entry requirements. Figure 7, shown below, illustrates the keys and keys used to perform the toll restriction table entries.

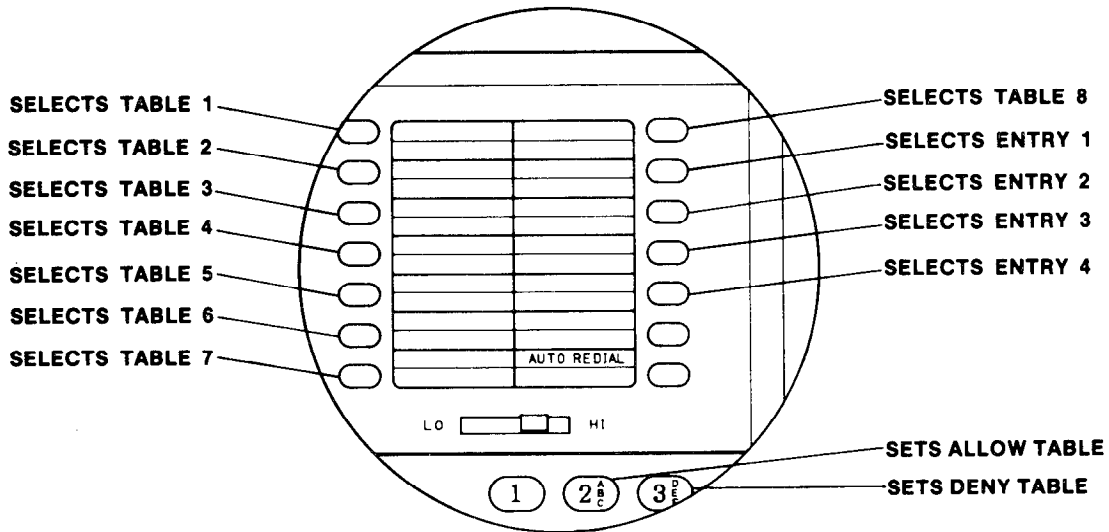

Figure 7. Toll Restriction Programming Keys

- a. Press a memory key (1 through 8) to select a toll restriction table (1 through 8). Key 1 selects table 1, key 2 selects table 2, etc. The dial tone will stop when the selection is made.
- b. Select the restriction mode of the table using a keypad key. A tone burst will sound to conform the selection.

<u>KEY</u>	<u>TABLE SELECTION</u>
② <sup>A</sup> <sub>B</sub> <sub>C</sub>	sets the table as an ALLOW table
③ <sup>D</sup> <sub>E</sub> <sub>F</sub>	sets the table as a DENY table

- c. Press a memory key (9 through 12) to choose the desired table entry per the following chart. This action clears any current entry and causes a continuous busy dial tone to sound.

<u>TABLE ENTRY</u>	<u>MEMORY KEY</u>
1	9
2	10
3	11
4	12

- d. Press the keypad keys (①<sup>O</sup><sub>P</sub><sub>R</sub>) through (⑨<sup>W</sup><sub>X</sub><sub>Y</sub>) to enter the digits of the desired restriction number as a table

entry. Press the keypad key  $\text{\textcircled{\#}^R}$  to enter a "match anything" digit if such an item is desired. A tone burst will sound after each key is pressed. A single table entry can contain a maximum of 16 digits. When the maximum number of digits are entered, the system sounds a fast ringback dial tone and steps to the next entry point on a table or to the next table.

- e. If less than the maximum number of digits are required as part of a table entry, select the next entry location with the proper memory key. Select each entry location even if no input is required. This action insures that any previous entry is erased. Erase a complete table, if desired, by selecting the table and then selecting each entry location in sequence. Do not dial any numbers after any of the entry location selections.
  - f. Repeat steps a. through e. until all toll restriction tables are programmed.
13. Press the  $\text{\textcircled{*}^S}$  key on the keypad. The dial tone will sound.
  14. Program the data speed baud rate (model 616B only) for the printer port. Press the  $\text{\textcircled{3}^D}$  keypad key to set a system data speed of 300 baud. Press the  $\text{\textcircled{0}^O}$  keypad key to set a system data speed of 110 baud. The system default condition sets a system data speed of 110 baud.
  15. Press the MONITOR key to exit the programming mode.

#### LINE COS

The Line COS programming sets the following line characteristics:



- Privacy status
- Line toll restriction requirements
- Line port type
- Dialing mode
- Time interval for held call abandon

1. Enter the base programming mode: Press  $\text{\textcircled{ITCM}}$   $\text{\textcircled{*}^S}$   $\text{\textcircled{7}^P}$   $\text{\textcircled{4}^H}$   $\text{\textcircled{6}^M}$   $\text{\textcircled{*}^S}$ . The dial tone will sound.
2. Set the privacy status of the lines per the following steps.
  - a. Press the  $\text{\textcircled{8}^I}$  key on the keypad. The dial tone will stop. This action initializes all lines as private. This condition is the system default value.
  - b. Press the line select key of each line which is to be non-private. A tone burst will sound after each selection to confirm it. The line status chosen will be in effect at every station in the system.

3. Press the  $\textcircled{\text{X}}^{\text{S}}$  key on the keypad. The dial tone will sound.
4. Press the line select key of the line to be set. The dial tone will stop. Any toll restriction currently assigned to the selected line will be disabled when the line select key is pressed.
- 5a. On Model 616B systems, assign the line specific toll restriction tables per the following procedure. At this point, all toll restriction tables are unassigned for the selected line.
  - a. Press a memory key for each table to be assigned to the line. Tables 1 through 8 correspond to the memory keys 1 through 8. A tone burst will sound with each selection.
  - b. Proceed with step 6 if other COS programming must be performed. If programming only the toll restriction requirements of a line, repeat step 5 until all lines are programmed.
- 5b. On Model 616 systems, assign the toll restriction status of a line.
  - a. Press  $\textcircled{4}^{\text{G}}$  to enable toll restriction on the line.
  - b. Press  $\textcircled{5}^{\text{J}}$  to disable toll restriction on the line.
6. Select the remaining line characteristics by pressing keys on the keypad to choose them per the following chart. A tone burst will sound after each selection to confirm it.

FEATURE	KEY	FUNCTION
LINE TYPE	0	LINE PORT DISABLED
	1	AUXILIARY PORT
	2	TELCO PORT (DEFAULT VALUE)
	3	PABX PORT
DIALING MODE	6	PULSE/TONE SWITCHABLE
	7	TONE ONLY (DEFAULT VALUE)
TIME INTERVAL FOR LINE RESTORE AFTER HOLD IS ABANDONED	8	50 MSEC.
	9	300 MSEC. (DEFAULT VALUE)







7. Repeat Steps 5 through 7 for each line.

8. Press the  key on the keypad. The dial tone will sound.
9. Press the  key to exit the programming mode.

## STATION COS



The Station COS programming sets the following station characteristics:

DSS/BLF port enable	Ringing assignments
PA port enable	Access denied
Prime line selection	Call origination denied
Ringing line preference status	Automatic privacy release
Station toll restriction requirements (616B only)	Night ringing assignment
	All-call and zone paging configuration (616B only)
	Line appearance/key assignment

1. Enter the base programming mode: Press      . The dial tone will sound.
2. Press a two-key sequence on the keypad which corresponds to the station to be set (i. e., to choose station 11 press 1 1 ). A tone burst will sound to confirm a proper selection. An improper selection will result in the dial tone sound indicating a return to the base level mode.

## NOTE

Each time the base programming mode is followed by a station select number, the following features are set to the default values: the DSS/BLF port enable, the PA port enable, the prime line selection, and the ringing line preference enable. Plus, the toll restriction table assignments are disabled.

3. Set the DSS/BLF console port enable (if such a port is required) by pressing the  key. A tone burst will sound to confirm the selection. Skip this step if a DSS/BLF console is not installed at the station port currently being programmed. If this feature is enabled, do not proceed beyond this step unless the port is also to be programmed as a PA port.
4. Set the PA port enable (only if a PA port is desired) by pressing  on the keypad. A tone burst will sound to confirm this selection. Skip this step if a PA port is not desired. Do not proceed beyond this step if a PA port selection is made.
5. Set a prime line for the station being programmed by pressing the line select key for the line desired or by pressing the ITCM key to select the intercom line. A tone burst will sound to confirm the selection. If more than one line selection key is pressed, the last one pressed selects the accepted prime line.

6. Enable the ringing line preference for the station if this feature is desired.

a. On Model 616B systems, press the **1** key on the keypad.

b. On Model 616 systems, press memory key 1 (top left key in memory key field).

7a. On Model 616B systems, set the station toll restriction by performing the steps listed below. At this point, there are no toll restriction tables assigned to this station.

a. Press a memory key for each table to be assigned to the station. Tables 1 through 8 correspond to the memory keys 1 through 8. A tone burst will sound with each selection.

b. Proceed with step 8 if other station COS programming must be performed. If only programming the toll restriction requirements of a station, proceed with step 16.

7b. On Model 616 systems, set the station toll restriction as follows. A tone burst will sound after each selection to confirm it. The system default disables station toll restriction.

a. Press **1** to restrict outgoing TELCO calls numbered 1-xxxx and PBX calls numbered x-1-xxxx.

b. Press **0<sup>o</sup><sub>R</sub>** to restrict outgoing TELCO calls numbered 0-xxxx and PBX calls numbered x-0-xxxx.

c. Press **1** and **0<sup>o</sup><sub>R</sub>** to restrict both tolls.

During an initial station programming sequence, perform all of the remaining programming steps given herein (8 - 14). It is recommended that they be performed in the order that they are presented. During subsequent reprogramming of a station, any step, controlling a feature that does not need to be reprogrammed, can be skipped over. It is not necessary to return to the base programming mode to shift from one programming step to another. A default value is automatically programmed for most of the following characteristics when the selection key is pressed. This default value is overridden by subsequent programming action.

#### IMPORTANT NOTE

STEP 15, WHICH SETS THE LINE APPEARANCE TO KEY ASSIGNMENT, MUST BE PERFORMED LAST. THIS IS NECESSARY BECAUSE THAT PROGRAMMING ACTION MUST BE IMMEDIATELY FOLLOWED BY A RETURN TO THE BASE PROGRAMMING MODE.

A line may be programmed for direct ringing (step 8) or delayed ringing (step 9) but not for both ringing features. If step 8 is programmed after step 9 for some reason, delayed ringing will be disabled.

8. Set the direct ring selection for each line.
  - a. Press the  $\textcircled{2}^{\text{A B C}}$  key. A tone burst will sound. A default condition of no ringing enabled will be set on all lines.
  - b. Press the line select key for each line on which direct ringing is desired. A tone burst will sound after each selection.
9. Set the delayed ring selection for each line.
  - a. Press the  $\textcircled{3}^{\text{D E F}}$  key. A tone burst will sound. A default condition of no delayed ringing enabled will be set on all lines.
  - b. Press the line select key for each line on which delayed ringing is desired. A tone burst will sound after each selection. The time of this delay is 15 seconds.
10. Set the access denied status for each line.
  - a. Press the  $\textcircled{4}^{\text{G H}}$  key. A tone burst will sound. A default condition of access not denied will be set on all lines.
  - b. Press the line select key for each line on which access is to be denied. A tone burst will sound after each selection.
11. Set the call origination denied status for each line.
  - a. Press the  $\textcircled{5}^{\text{I J K L}}$  key. A tone burst will sound. A default condition of call origination not denied will be set on all lines.
  - b. Press the line select key for each line on which call origination is to be denied. A tone burst will sound after each selection.
12. Set the access to automatic privacy release for each line.
  - a. Press the  $\textcircled{6}^{\text{M N O}}$  key. A tone burst will sound. A default condition of no access to automatic privacy release will be set on all lines.
  - b. Press the line select key for each line on which access to automatic privacy release is desired. A tone burst will sound after each selection.
13. Set the night ringing status for each line.

- a. Press the **(8<sup>TUV</sup>)** key. A tone burst will sound. A default condition of no night ringing will be set on all lines.
  - b. Press the line select key for each line on which night ringing is desired. A tone burst will sound after each selection.
14. Set the All-Call And Zone Paging capability (model 616B only) for the station. The system default value fixes all call at all stations in the system.
- a. Press the **(#<sup>R</sup><sub>D</sub>)** key. A tone burst will sound. This action clears the station from zones A, B, and C.
  - b. If it is desired to clear the station from all call, press the **(ITCM)** key.
  - c. To assign reception by zone:
    1. Press line select key 1 for zone A
    2. Press line select key 2 for zone B
    3. Press line select key 3 for zone C.
    4. Press line select key 4 for all call (if it was cleared in step b).
  - d. To enable origination by zone:
    1. Press line select key 5 for zone A
    2. Press line select key 6 for zone B
    3. Press line select key 7 for zone C
    4. Press line select key 8 for all call (if it was cleared in step b).

## NOTE

Step 15 must be performed last. See previous important note.

15. Set the line appearance to key assignment only if current settings are not correct. When power was initially applied to the KSU, the system set the line appearance to key assignment so that line 1 matched select key 1, line 2 matched select key 2, etc. (squared pairing). If this squared pairing is desired, skip step 15a and b.
- a. Press the **(7<sup>P</sup><sub>S</sub>)** key on the keypad. A tone burst will sound. There is no default condition set by pressing this key.
  - b. Assign the pairing. Any desired pairing can be set. All line select keys can be programmed to select the same line if such a condition is desired.

(1) Press a line select key. A tone burst will sound.





- (2) Press the keypad key that represents the line to be paired. Another tone burst will sound.
  - (3) Repeat this sequence for every line select key.
- c. Disable the line select key and the indicator light for any lines which are unassigned to a particular station:
- (1) Press the line select key for the unassigned line:
  - (2) Press the  key on the keypad.
  - (3) Repeat this action for each unassigned line.
16. Press the  key to return to the base programming mode.
17. Repeat steps 1 through 16 for each station connected to the system.
18. Press the  key to exit the programming mode.

Table 2a. SYSTEM COS PROGRAMMING REFERENCE

PROCEDURE	RECORD (Shading Denotes System Default Values)																														
<p style="text-align: center;"><b>NOTE</b></p> <p>Circle the record values at right before performing the programming procedure given below.</p>	<p style="text-align: center;"><b>NOTE</b></p> <p>Circle the desired value for the system being programmed.</p>																														
<p>1. Base level program entry</p> <p>a. Press INTERCOM</p> <p>b. Press <input type="checkbox"/>*</p> <p>c. Press, in sequence, <input type="checkbox"/>7 <input type="checkbox"/>4 &amp; <input type="checkbox"/>6</p> <p>d. Press <input type="checkbox"/>*</p>																															
<p>2. Press <input type="checkbox"/>#</p> <p>3. Press <input type="checkbox"/>0 (TONE DIALING)</p> <p>or</p> <p>Press <input type="checkbox"/>1 (PULSE/TONE DIALING)</p> <p>4. Press <input type="checkbox"/>*</p>	<p>SYSTEM DIALING MODE</p> <p><input checked="" type="checkbox"/>TONE ONLY    <input type="checkbox"/>PULSE TONE SWITCHABLE</p>																														
<p>5. Press memory key 13 for tone signalling Intercom.</p> <p>OR</p> <p>Press memory key 14 for voice signalling Intercom.</p>	<p>FIRST ATTEMPTED INTERCOM SIGNALLING MODE</p> <p><input checked="" type="checkbox"/>VOICE SIGNALLING    <input type="checkbox"/>TONE SIGNALLING</p>																														
<p>6. Press <input type="checkbox"/>4 (PAUSE INTERVAL IN SECONDS — speed/auto dial)</p> <p>7. Press one key</p> <table border="1" data-bbox="431 570 857 630"> <tr><td>.1</td><td>2</td><td>3</td><td>4</td><td>5</td><td>6</td><td>7</td><td>8</td><td>9</td><td>0</td></tr> <tr><td>0.5</td><td>1.0</td><td>1.5</td><td>2.0</td><td>3.0</td><td>5.0</td><td>7.5</td><td>10.</td><td>15.</td><td>20.</td></tr> </table> <p>8. Press <input type="checkbox"/>*</p>	.1	2	3	4	5	6	7	8	9	0	0.5	1.0	1.5	2.0	3.0	5.0	7.5	10.	15.	20.	<p>PAUSE INTERVAL IN SECONDS</p> <table border="1" data-bbox="1055 565 1410 594"> <tr><td>0.5</td><td><input checked="" type="checkbox"/>1.0</td><td>1.5</td><td>2.0</td><td>3.0</td><td>5.0</td><td>7.5</td><td>10.</td><td>15.</td><td>20.</td></tr> </table>	0.5	<input checked="" type="checkbox"/> 1.0	1.5	2.0	3.0	5.0	7.5	10.	15.	20.
.1	2	3	4	5	6	7	8	9	0																						
0.5	1.0	1.5	2.0	3.0	5.0	7.5	10.	15.	20.																						
0.5	<input checked="" type="checkbox"/> 1.0	1.5	2.0	3.0	5.0	7.5	10.	15.	20.																						
<p>9. Press <input type="checkbox"/>5 (PULSE DIAL TIMES — PPI &amp; BREAK/MAKE)</p> <p>10. Press one key</p> <table border="1" data-bbox="431 724 683 816"> <thead> <tr><th>KEY</th><th>PULSE DIAL TIMES</th></tr> </thead> <tbody> <tr><td>1</td><td>10 PPI &amp; 60/40</td></tr> <tr><td>2</td><td>20 PPI &amp; 60/40</td></tr> </tbody> </table> <p>11. Press <input type="checkbox"/>*</p>	KEY	PULSE DIAL TIMES	1	10 PPI & 60/40	2	20 PPI & 60/40	<p>PULSE DIAL TIMES (PPI &amp; BREAK/MAKE)</p> <p><input checked="" type="checkbox"/>10 PPI &amp; 60/40</p> <p><input type="checkbox"/>20 PPI &amp; 60/40</p>																								
KEY	PULSE DIAL TIMES																														
1	10 PPI & 60/40																														
2	20 PPI & 60/40																														
<p>12. Press <input type="checkbox"/>6 (TRANSFER ACCESS INTERVAL IN SECONDS)</p> <p>13. Press one key</p> <table border="1" data-bbox="431 889 949 950"> <tr><td>1</td><td>2</td><td>3</td><td>4</td><td>5</td><td>6</td><td>7</td><td>8</td><td>9</td><td>0</td></tr> <tr><td>.08</td><td>.30</td><td>.50</td><td>.60</td><td>.75</td><td>.875</td><td>1.0</td><td>1.5</td><td>2.0</td><td>3.0</td></tr> </table> <p>14. Press <input type="checkbox"/>*</p>	1	2	3	4	5	6	7	8	9	0	.08	.30	.50	.60	.75	.875	1.0	1.5	2.0	3.0	<p>TRANSFER ACCESS INTERVAL IN SECONDS</p> <table border="1" data-bbox="1055 889 1517 919"> <tr><td>.08</td><td>.30</td><td>.50</td><td>.60</td><td>.75</td><td>.875</td><td>1.0</td><td>1.5</td><td><input checked="" type="checkbox"/>2.0</td><td>3.0</td></tr> </table>	.08	.30	.50	.60	.75	.875	1.0	1.5	<input checked="" type="checkbox"/> 2.0	3.0
1	2	3	4	5	6	7	8	9	0																						
.08	.30	.50	.60	.75	.875	1.0	1.5	2.0	3.0																						
.08	.30	.50	.60	.75	.875	1.0	1.5	<input checked="" type="checkbox"/> 2.0	3.0																						
<p>15. Press <input type="checkbox"/>7 (HOLD RECALL INTERVAL IN SECONDS)</p> <p>16. Press one key</p> <table border="1" data-bbox="431 1024 921 1084"> <tr><td>1</td><td>2</td><td>3</td><td>4</td><td>5</td><td>6</td><td>7</td><td>8</td><td>9</td><td>0</td></tr> <tr><td>30</td><td>60</td><td>90</td><td>120</td><td>180</td><td>240</td><td>300</td><td>360</td><td>420</td><td>NONE</td></tr> </table> <p>* 17. Press <input type="checkbox"/>*</p>	1	2	3	4	5	6	7	8	9	0	30	60	90	120	180	240	300	360	420	NONE	<p>HOLD RECALL INTERVAL IN SECONDS</p> <table border="1" data-bbox="1055 1024 1587 1053"> <tr><td><input checked="" type="checkbox"/>30</td><td>60</td><td>90</td><td>120</td><td>180</td><td>240</td><td>300</td><td>360</td><td>420</td><td>NONE</td></tr> </table>	<input checked="" type="checkbox"/> 30	60	90	120	180	240	300	360	420	NONE
1	2	3	4	5	6	7	8	9	0																						
30	60	90	120	180	240	300	360	420	NONE																						
<input checked="" type="checkbox"/> 30	60	90	120	180	240	300	360	420	NONE																						
<p>* 18. Set system toll restriction requirements per instructions given on Table 2d, TOLL RESTRICTION PROGRAMMING REFERENCE.</p>	<p>Record all toll restriction data on Table 2d. TOLL RESTRICTION PROGRAMMING REFERENCE</p>																														
<p>19. Set baud rate for printer data: Press <input type="checkbox"/>3 for 300 baud Press <input type="checkbox"/>0 for 110 baud</p> <p>20. Press <input type="checkbox"/>*</p>	<p><input checked="" type="checkbox"/>300 BAUD    <input type="checkbox"/>110 BAUD</p> <p>PRINTER BAUD RATE</p>																														
<p>21. Press <input type="checkbox"/>MONITOR</p>																															
<p style="text-align: center;"><b>NOTE</b></p> <p>If a time out occurs during the programming sequence, perform base level entry again and proceed at any program step.</p>																															
<p>*Steps 17 and 18 are not applicable on Model 616 systems.</p>																															

Table 2b. LINE COS PROGRAMMING REFERENCE

PROCEDURE	RECORD (Shading Denotes System Default Values)						
<b>NOTE</b> Enter the information in the box at right before performing the programming procedures given below.	<b>NOTE</b>						
1. Base level program entry a. Press <b>INTERCOM</b> b. Press <b>*</b> c. Press, in sequence, <b>7</b> <b>4</b> & <b>6</b> d. Press <b>*</b>	<ul style="list-style-type: none"> <li>• Check each line number block for the line feature that is set.</li> <li>• Write in the calling number and location status.</li> </ul>						
	<b>FEATURE SETTING</b>	<b>LINE NUMBER (Check Block)</b>					
		1	2	3	4	5	6
2. Press <b>8</b> (SET ALL LINES PRIVATE)	PRIVATE						
3. Press <b>LINE SELECT</b> 1-6 (SET NON-PRIVATE LINES)	NON-PRIVATE						
4. Press <b>*</b>	DISABLED						
5. Press <b>LINE SELECT</b> 6. Press <b>0</b> (DISABLED LINE) 6. <b>1</b> (AUXIL LINE) 6. <b>2</b> (TELCO LINE) 6. <b>3</b> (PBX LINE)	AUXIL						
	TELCO						
	PABX						
	1						
	2						
7. Select toll restriction tables —Press memory keys (1) selects table 1 (2) selects table 2 (3) selects table 3 (4) through (8) selects tables 4 through 8	TOLL	3					
	RESTRICTION	4					
	TABLES	5					
	6						
	7						
	8						
	PULSE/TONE						
	TONE ONLY						
8. Press <b>6</b> (PULSE/TONE DIALING) Press <b>7</b> (TONE ONLY DIALING)	HOLD ABANDON	50ms					
	TIMEOUT	300 ms					
9. Press <b>8</b> (HOLD ABANDON 50ms) Press <b>9</b> (HOLD ABANDON 300ms)							
10. Repeat steps 5 through 9 for each line	CALLING NO.						
11. Press <b>*</b>							
12. Press <b>MONITOR</b>	LOCATION ASSGN.						
<b>NOTE</b> If a time out occurs during the programming sequence, perform base level entry again and proceed at program step 2 or 4.							

Table 2c. STATION COS PROGRAMMING REFERENCE  
(Copy this sheet as required)

PROGRAMMING	RECORD (Shading Denotes System Default Values)																														
<p><b>NOTE</b> Circle or enter the record values at right before proceeding with the programming procedure given below.</p>	<p><b>NOTE</b> Enter information or circle desired values below before performing the programming procedure given on the left.</p>																														
<p>1. Base level program entry a. Press <b>INTERCOM</b> b. Press <b>*</b> c. Press, in sequence, <b>7</b> <b>4</b> &amp; <b>6</b> d. Press <b>*</b></p>	<p>Station Location:</p>																														
<p>2. Press two keys for station number (i.e. <b>1</b> <b>2</b> - 12)</p>	<p>Station Intercom Number:</p>																														
<p>3. Press <b>RECALL</b> (DSS/BLF CONSOLE PORT)</p>	<p>DSS/BLF Console Port <b>YES</b> <b>NO</b></p>																														
<p>4. Press <b>9</b> (PA PORT)</p>	<p>PA Port <b>YES</b> <b>NO</b></p>																														
<p>5. Press <b>1</b> (Model 616 B) (RINGING LINE PREFERENCE) or Press memory key 1 (Model 616)</p>	<p>Ringling Line Preference <b>YES</b> <b>NO</b></p>																														
<p>6. Press one <b>LINE SELECT</b> or (PRIME LINE) Press <b>ITCM</b></p>	<p>Prime Line <b>1</b> <b>2</b> <b>3</b> <b>4</b> <b>5</b> <b>6</b> <b>ITCM</b> <b>NONE</b></p>																														
<p>7. Select toll restriction tables (Model 616 B) —Press memory keys <b>1</b> selects table 1 <b>2</b> selects table 2 <b>3</b> selects table 3 <b>4</b> through <b>8</b> selects tables 4 through 8</p>	<p>Toll Restriction Tables <b>1</b> <b>2</b> <b>3</b> <b>4</b> <b>5</b> <b>6</b> <b>7</b> <b>8</b> <b>NONE</b></p>																														
<p>8. Select 1-0 toll restriction (Model 616) —Press <b>0</b> , <b>1</b> or both</p>	<p>Toll Restriction <b>1</b> <b>0</b> <b>NONE</b></p>																														
<p>9. Press <b>2</b> (DIRECT RINGING)</p>	<p>Ringling* <b>1</b> <b>2</b> <b>3</b> <b>4</b> <b>5</b> <b>6</b> <b>NONE</b></p>																														
<p>10. Press all desired <b>LINE SELECT</b> (1-6)</p>																															
<p>11. Press <b>3</b> (DELAYED RING)</p>	<p>Delayed Ringling <b>1</b> <b>2</b> <b>3</b> <b>4</b> <b>5</b> <b>6</b> <b>NONE</b></p>																														
<p>12. Press all desired <b>LINE SELECT</b> (1-6)</p>																															
<p>13. Press <b>4</b> (ACCESS DENIED)</p>	<p>Access Denied <b>1</b> <b>2</b> <b>3</b> <b>4</b> <b>5</b> <b>6</b> <b>NONE</b></p>																														
<p>14. Press all desired <b>LINE SELECT</b> (1-6)</p>																															
<p>15. Press <b>5</b> (CALL ORIGINATION DENIED)</p>	<p>Orig. Denied <b>1</b> <b>2</b> <b>3</b> <b>4</b> <b>5</b> <b>6</b> <b>NONE</b></p>																														
<p>16. Press all desired <b>LINE SELECT</b> (1-6)</p>																															
<p>17. Press <b>6</b> (PRIVACY RELEASED)</p>	<p>Auto Priv. Rel. <b>1</b> <b>2</b> <b>3</b> <b>4</b> <b>5</b> <b>6</b> <b>NONE</b></p>																														
<p>18. Press all desired <b>LINE SELECT</b> (1-6)</p>																															
<p>19. Press <b>8</b> (NIGHT ANSWER RINGING)</p>	<p>Night Ringling* <b>1</b> <b>2</b> <b>3</b> <b>4</b> <b>5</b> <b>6</b> <b>NONE</b></p>																														
<p>20. Press all desired <b>LINE SELECT</b> (1-6)</p>																															
<p>21a. Press <b>#</b> (Clears Zones A, B &amp; C) 21b. Press <b>#</b> <b>ITCM</b> (Clears all call, if desired) 22. Press <b>LINE SELECT</b> 1-4 (Receive Zone A, B, C, All Call) 23. Press <b>LINE SELECT</b> 5-8 (Originate Zone A, B, C, All Call)</p>	<table border="1" style="width: 100%; text-align: center;"> <tr><th colspan="5">RECEIVE ALL CALL</th></tr> <tr><td>Zone Number</td><td>A</td><td>B</td><td>C</td><td>ALL CALL</td></tr> <tr><td>Line Select Number</td><td>1</td><td>2</td><td>3</td><td>4</td></tr> </table> <table border="1" style="width: 100%; text-align: center;"> <tr><th colspan="5">ORIGINATE ALL CALL</th></tr> <tr><td>Zone Number</td><td>A</td><td>B</td><td>C</td><td>ALL CALL</td></tr> <tr><td>Line Select Number</td><td>5</td><td>6</td><td>7</td><td>8</td></tr> </table>	RECEIVE ALL CALL					Zone Number	A	B	C	ALL CALL	Line Select Number	1	2	3	4	ORIGINATE ALL CALL					Zone Number	A	B	C	ALL CALL	Line Select Number	5	6	7	8
RECEIVE ALL CALL																															
Zone Number	A	B	C	ALL CALL																											
Line Select Number	1	2	3	4																											
ORIGINATE ALL CALL																															
Zone Number	A	B	C	ALL CALL																											
Line Select Number	5	6	7	8																											
<p>24. Press <b>7</b> (LINE APPEARANCE/BUTTON ASSIGN.). 25. Press one <b>LINE SELECT</b> (Key 1-6) 26. Press key for selected line <b>1</b> - <b>6</b> 27. Repeat steps 25 and 26 for each assigned line 28. Press <b>LINE SELECT</b> of unused line 29. Press <b>9</b> to disable key and light 30. Repeat steps 28 and 29 for each unused line 31. Press <b>*</b> 32. Press <b>MONITOR</b></p>	<table border="1" style="width: 100%; text-align: center;"> <tr><th>Line Select Key</th><td>1</td><td>2</td><td>3</td><td>4</td><td>5</td><td>6</td><td>7</td><td>8</td><th>SQUARE</th></tr> <tr><th>Line Assigned (If unassigned—so note here)</th><td></td><td></td><td></td><td></td><td></td><td></td><td></td><td></td><td>Keys 1-8 Selects Lines 1-8</td></tr> </table> <table border="1" style="width: 100%; text-align: center;"> <tr><th colspan="2">Line Select Key</th></tr> <tr><td>1 2 3</td><td>4 5 6 7 8</td></tr> </table> <div style="display: flex; justify-content: space-around;"> <div style="text-align: center;">  <p>Desig. Strip 1</p> </div> <div style="text-align: center;">  <p>Desig. Strip 2</p> </div> </div> <p style="text-align: right;">Calling Number Assigned</p>	Line Select Key	1	2	3	4	5	6	7	8	SQUARE	Line Assigned (If unassigned—so note here)									Keys 1-8 Selects Lines 1-8	Line Select Key		1 2 3	4 5 6 7 8						
Line Select Key	1	2	3	4	5	6	7	8	SQUARE																						
Line Assigned (If unassigned—so note here)									Keys 1-8 Selects Lines 1-8																						
Line Select Key																															
1 2 3	4 5 6 7 8																														
<p><b>NOTE</b> If a time out occurs during the programming sequence, perform base level entry again and proceed at program step 2. Re-enter the station number that was active at time out.</p>	<p style="text-align: center;">* Ringling defaults to all lines on stations 10, 17 &amp; 24</p>																														

Table 2d. TOLL RESTRICTION PROGRAMMING REFERENCE

**HOW TO FILL OUT THE TOLL RESTRICTION TABLES**

1. Determine the types of dialing restrictions which must be imposed on the system. Typically, this includes access codes which result in toll charges, and certain local numbers as desired.
2. If the restricted dialing codes will be imposed consistently on most or all stations in the system, list them on one or two entry tables. If a wide variation in the dialing restrictions is planned, spread the listings out across several tables.
3. Strategically group the listings on the tables so that a list of restrictions can be applied to a particular station or stations.
4. Press a **#** key in place of a particular digit to condense a series of restricted codes into one listing. For example, if 357, 387, and 397 are to be restricted digits, one entry of 3 # 7 can be listed to cover them all.

Enter # 1 # and # 0 # to restrict all 3-digit access codes with a 1 or 0 as a middle digit.

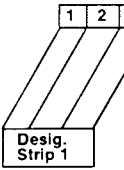
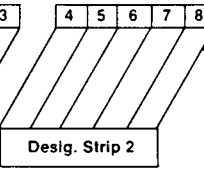
5. Designate each table as a DENY table or as an ALLOW table. All entries on a DENY table are dialing restricted entries. All ALLOW table entries allows certain override conditions to prevail. A typical example follows: A DENY table may contain entries which restricts the dialing of 1 804 while an ALLOW table may contain entries which do not restrict the dialing of 1 800. Another typical entry on an ALLOW table is a PBX outside line access code. This entry will allow a toll restricted station to have access to an outside line for an unrestricted use.
6. Once these tables are completely filled out, enter this restriction planning on tables 2b and 2c so that the line and station programming reference records reflect the planned toll restrictions for the system.

**HOW TO PROGRAM THE TOLL RESTRICTION REQUIREMENTS**

1. Fill out the following restriction tables per the above instructions.
2. Press **ITCM** **\*** **7** **4** **6** **\***  
—sets base level programming mode if not now active.
3. Select a table: Press memory key.  
— **1** selects table 1  
— **2** selects table 2  
— **3** selects table 3  
— **4** through **8** selects tables 4 through 8
4. Set the table mode: Press keypad key.  
— **2** for ALLOW table.  
— **3** for DENY table.
5. Select a table entry: Press memory key.  
— **9** selects entry 1  
— **10** selects entry 2  
— **11** selects entry 3  
— **12** selects entry 4  
— new entry selection clears current entry.

6. Dial the restricted number from the keypad.  
— maximum of 16 digits allowed.  
— dial **#** for "match anything" digit.
7. Select another table entry: repeat step 5.  
— automatic selection of next entry point occurs after 16th digit is dialed in preceding entry.
8. Make entry for all four table entry points: repeat steps 5 through 7.
9. Select another table: repeat step 3.  
— automatic table selection occurs after 16th digit is dialed in 4th entry of preceding table.
10. Repeat steps 3 through 8 until all desired toll restriction tables are created.
11. Press **\***
12. Press **MONITOR** or proceed to next system COS programming step as found on Table 2a.

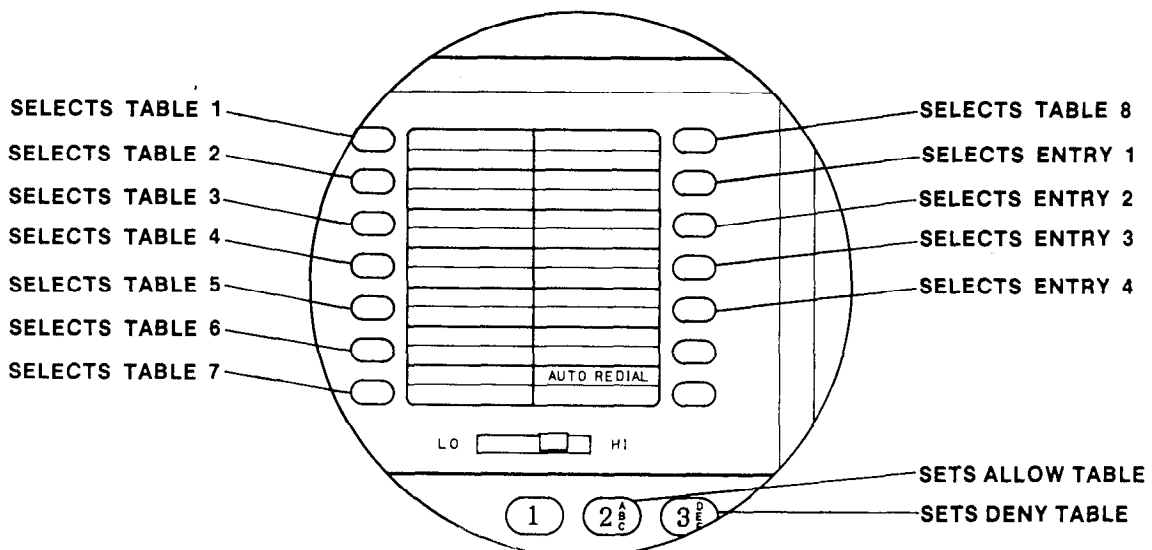

Table 2d. TOLL RESTRICTION REFERENCE

RESTRICTION TABLE 1 (PRESS MEMORY KEY)																
CHOOSE EITHER MODE: ALLOW _____ (PRESS KEYPAD KEY 2) DENY _____ (PRESS KEYPAD KEY 3)																
PRESS MEMORY KEY TO SELECT ENTRY POINT		MANUALLY DIAL RESTRICTED NUMBER (16 MAXIMUM)														
		D1	D2	D3	D4	D5	D6	D7	D8	D9	D10	D11	D12	D13	D14	D15
BUTTON	ENTRY															
9	1															
10	2															
11	3															
12	4															
TABLE ASSIGNMENT: LINES _____ STATIONS _____																

RESTRICTION TABLE 2 (PRESS MEMORY KEY)																
CHOOSE EITHER MODE: ALLOW _____ (PRESS KEYPAD KEY 2) DENY _____ (PRESS KEYPAD KEY 3)																
PRESS MEMORY KEY TO SELECT ENTRY POINT		MANUALLY DIAL RESTRICTED NUMBER (16 MAXIMUM)														
		D1	D2	D3	D4	D5	D6	D7	D8	D9	D10	D11	D12	D13	D14	D15
BUTTON	ENTRY															
9	1															
10	2															
11	3															
12	4															
TABLE ASSIGNMENT: LINES _____ STATIONS _____																

RESTRICTION TABLE 3 (PRESS MEMORY KEY)																
CHOOSE EITHER MODE: ALLOW _____ (PRESS KEYPAD KEY 2) DENY _____ (PRESS KEYPAD KEY 3)																
PRESS MEMORY KEY TO SELECT ENTRY POINT		MANUALLY DIAL RESTRICTED NUMBER (16 MAXIMUM)														
		D1	D2	D3	D4	D5	D6	D7	D8	D9	D10	D11	D12	D13	D14	D15
BUTTON	ENTRY															
9	1															
10	2															
11	3															
12	4															
TABLE ASSIGNMENT: LINES _____ STATIONS _____																

RESTRICTION TABLE 4 (PRESS MEMORY KEY)																
CHOOSE EITHER MODE: ALLOW _____ (PRESS KEYPAD KEY 2) DENY _____ (PRESS KEYPAD KEY 3)																
PRESS MEMORY KEY TO SELECT ENTRY POINT		MANUALLY DIAL RESTRICTED NUMBER (16 MAXIMUM)														
		D1	D2	D3	D4	D5	D6	D7	D8	D9	D10	D11	D12	D13	D14	D15
BUTTON	ENTRY															
9	1															
10	2															
11	3															
12	4															
TABLE ASSIGNMENT: LINES _____ STATIONS _____																

Table 2d. TOLL RESTRICTION REFERENCE

RESTRICTION TABLE 5 (PRESS MEMORY KEY)																	
CHOOSE EITHER MODE: ALLOW _____ (PRESS KEYPAD KEY 2) DENY _____ (PRESS KEYPAD KEY 3)																	
PRESS MEMORY KEY TO SELECT ENTRY POINT		MANUALLY DIAL RESTRICTED NUMBER (16 MAXIMUM)															
BUTTON	ENTRY	D1	D2	D3	D4	D5	D6	D7	D8	D9	D10	D11	D12	D13	D14	D15	D16
9	1																
10	2																
11	3																
12	4																
TABLE ASSIGNMENT: LINES _____ STATIONS _____																	

RESTRICTION TABLE 6 (PRESS MEMORY KEY)																	
CHOOSE EITHER MODE: ALLOW _____ (PRESS KEYPAD KEY 2) DENY _____ (PRESS KEYPAD KEY 3)																	
PRESS MEMORY KEY TO SELECT ENTRY POINT		MANUALLY DIAL RESTRICTED NUMBER (16 MAXIMUM)															
BUTTON	ENTRY	D1	D2	D3	D4	D5	D6	D7	D8	D9	D10	D11	D12	D13	D14	D15	D16
9	1																
10	2																
11	3																
12	4																
TABLE ASSIGNMENT: LINES _____ STATIONS _____																	

RESTRICTION TABLE 7 (PRESS MEMORY KEY)																	
CHOOSE EITHER MODE: ALLOW _____ (PRESS KEYPAD KEY 2) DENY _____ (PRESS KEYPAD KEY 3)																	
PRESS MEMORY KEY TO SELECT ENTRY POINT		MANUALLY DIAL RESTRICTED NUMBER (16 MAXIMUM)															
BUTTON	ENTRY	D1	D2	D3	D4	D5	D6	D7	D8	D9	D10	D11	D12	D13	D14	D15	D16
9	1																
10	2																
11	3																
12	4																
TABLE ASSIGNMENT: LINES _____ STATIONS _____																	

RESTRICTION TABLE 8 (PRESS MEMORY KEY)																	
CHOOSE EITHER MODE: ALLOW _____ (PRESS KEYPAD KEY 2) DENY _____ (PRESS KEYPAD KEY 3)																	
PRESS MEMORY KEY TO SELECT ENTRY POINT		MANUALLY DIAL RESTRICTED NUMBER (16 MAXIMUM)															
BUTTON	ENTRY	D1	D2	D3	D4	D5	D6	D7	D8	D9	D10	D11	D12	D13	D14	D15	D16
9	1																
10	2																
11	3																
12	4																
TABLE ASSIGNMENT: LINES _____ STATIONS _____																	

## CHAPTER 5 MAINTENANCE

### SECTION 1 TECHNICAL ASSISTANCE AND REPAIR SERVICE

#### Technical Assistance

Should you experience difficulty with installation, checkout, or programming, and have made an attempt to isolate the problem using information provided herein; or should you encounter problems at a later date which cannot be resolved by referring to this manual, call the Comdial Technical Service staff. They can be reached at 800-431-4345 (in Virginia: 800-654-3345) between the hours of 8:00 AM and 8:00 PM Eastern time, Monday through Friday.

When calling for technical assistance, you should be at the job site and you should have in your possession, as a minimum, an accurate volt-ohm meter and a copy of this manual.

#### Repair Service

If your KSU or an individual station needs repair, subsequent to the warranty period, it may be returned to Comdial. Comdial will, at their option, either repair the defective equipment or replace it with a remanufactured unit. This repair will be done for a fixed charge. For information on this charge, please call or write to the address given below.

Comdial Corporation  
1180 Seminole Trail  
P.O. Box 7266  
Charlottesville, VA 22906-7266  
Attention: Repair Department  
Telephone: (804) 978-2400

When returning equipment for repair, pack it carefully to prevent damage. Any damages during shipment will be the responsibility of the purchaser. The equipment should be shipped freight or postage prepaid.

### SECTION 2 TROUBLESHOOTING

#### FUSE LOCATION

The KSU is protected against short circuit damage by a fuse located in the primary of the AC transformer winding. Fuse FS-1 is a 1 amp, 250V, SLO-BLO type fuse. The fuse holder is located near the top of the right side of the KSU cabinet. Always replace this fuse with one of the same value and type, otherwise, equipment damage could result.



## FAILURE ISOLATION

System Status Indicator

The red LED located near the fuse holder is the system status indicator. This indicator should turn on steady when AC power is applied to the KSU. If the indicator flashes after power up, it could be indicating a processor failure. Unplug and reconnect the AC power to the KSU and observe the LED indication.

Station Self Test

Exercise the station self test feature as follows:

1. Disconnect the line cord at the station base.

## IMPORTANT NOTE

THE ADJACENT ODD OR EVEN STATION WILL BE DISABLED DURING THE TIME THAT THE STATION LINE CORD IS BEING DISCONNECTED OR RECONNECTED.

2. Press and hold the MUTE button, and reconnect the line cord to the station connector. The station will automatically perform a self test routine. Release the MUTE button as soon as the test begins. The sequence of the test is as follows:
  - a. The line select indicators will light in sequence from 1 to 8.
  - b. The intercom select indicator will light.
  - c. The speaker indicator will light.
  - d. All indicators will turn off in the same sequence.
  - e. The ringer will sound - Be sure that the ringer volume control is set to the medium or high volume setting.
3. Replace any station that does not pass the self test.

DSS/BLF Console Self Test

Test the DSS/BLF Console for proper lamp operation per the following procedure.

1. Disconnect the console line cord plug from the line.
2. Press and hold the station 10 select button while reconnecting the line cord plug to the line.

## IMPORTANT NOTE

THE COMPANION STATION WILL BE DISABLED DURING THE TIME THAT THE CONSOLE IS BEING DISCONNECTED AND RECONNECTED.

3. Release the station 10 select button, and note that the BLF indicators will each turn on in sequence beginning with the station 10 indicator. The indicators will then turn off and the console will become operational.

### Paired Stations

#### Data Line Pairing

All stations are even/odd paired on the data lines as shown in Table 3. Station 10 is paired with station 11, etc. If erratic light indications or ring signals occur at a paired station, an open data pair at either station may be the fault. A station with an open data line may work properly on a short loop but fail on a long loop. Test the station wiring per the checkout procedure given in Chapter 2.

#### Overload Pairing

All stations are paired as shown in Table 3 for overload current protection. If a fault occurs which causes more than 300 ma. of current to be drawn, the paired stations are disabled by circuit action. Disconnect the disabled stations and reconnect them one at a time to isolate the faulty one.

Table 3. Station Pairing

DATA LINE PAIRING	OVERLOAD PAIRING
10--11	10--12
12--13	11--13
14--15	14--16
16--17	15--17
18--19	18--20
20--21	19--21
22--23	22--24
24--25	23--25

### Failure Analysis

Figure 8 details a failure analysis flow chart to assist a service technician in isolating a failure in a defective system. One way to isolate a failure is to substitute a known good assembly for a suspected one. This is the recommended failure isolation method to use with the system.

Connecting and disconnecting stations to the system does not affect the stored station auto/speed dial memory data. This data is stored in the KSU memory and not at the individual stations. Replacing the KSU, however, causes all stored memory to be lost. This includes all memory dialing numbers as well as all COS programming data.

System Default

Default conditions can be reset, whenever the system is operating, per the following instructions.

1. Press the **ITCM** button.
2. Press the following keys: **\*SYS** **7DSS** **4GHI** **6MNO** **\*SYS** **#RDL** **0OPR** **\*SYS**
3. Press the MONITOR button.

The following system default conditions are set:

- All lines are DTMF
- Voice signalling attempted first when intercom call is made
- 1 sec. pause time
- 2 sec. dial tone recall time
- 30 sec. recall from hold
- All lines private
- All lines are CO lines
- No toll restriction set
- 300 msec. held call abandon time
- No ringing line preference enabled
- No prime line is chosen
- DSS/BLF port is disabled
- PA port is disabled
- No delayed ringing enabled
- No access denied
- No origination denied
- No automatic privacy released
- Day and night ringing patterns set as follows:
  - station 10, 17, and 24 all lines
- System-wide, all call paging in zone D (model 616B only)
- Printer port set for 110 baud data rate (model 616B only)
- Line select buttons 1-n selects lines 1-n (squared pairing)

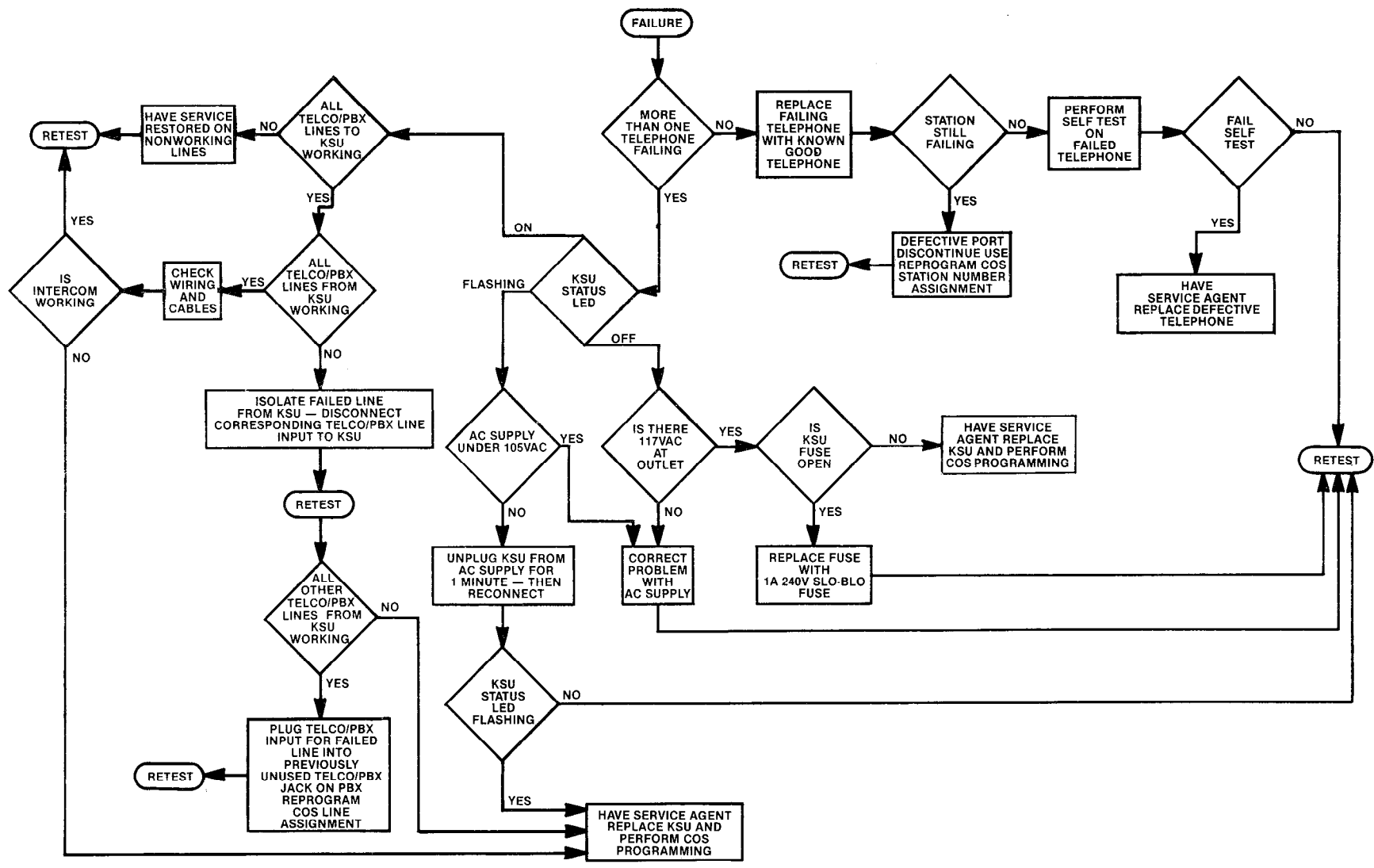

75

Figure 8. Failure Analysis Flow Chart

SECTION 3  
REPLACEMENT PARTS

<u>ORDER CODE</u>	<u>DESCRIPTION OF PART</u>
616B KSU	Key Service Unit, 6 Lines, 16 Stations
3503-xx-CT-900M	Electronic Key Telephone, 3-Line
3593-xx-CT-900M	Same as 3503 with Speakerphone option
3508-xx-CT-900M	Electronic Key Telephone, 8-Line
3598-xx-CT-900M	Same as 3508 with Speakerphone option
3508-xx-CT-935M	8-Line Key Telephone with 14-Station BLF
DSS-BLF-24-xx	DSS/BLF Console, 24-Key DSS, 24-LED BLF
703500-990	Fuse, KSU Power Supply, 1A, 250V, SLO-BLO
300001-911	Number Card, Station ID
303944-518	Number Card Cover, Station ID
703508-343	Index Card, Memory Key Location
703508-388	Index Card Cover, Memory Key Location
703500-604	Index Card, Pull Out Reference Strip
703500-560	Lens Assembly, Pull Out Reference Strip
703508-343	Designation Strip, Line Select Buttons
703508-390	Designation Strip Cover
703802-337	Designation Strip Package, includes 50 number cards 50 memory key index cards/design. strips 50 pull-out reference index cards 5 number card covers 5 memory key index covers 5 pull-out reference covers 5 designation strip covers
KA-M-xx	Handset
	Handset Cord
H4DU-6-M-xx	6-foot length
H4DU-9-M-xx	9-foot length
H4DU-12-M-xx	12-foot length
	Line Cord, 4-Wire, Flat
703805-185	10-Inch
D4BU-7	7-Foot
D4BU-14	14-Foot
D4BU-25	25-Foot
703500-550	Cable Assembly, Data Printer
701032-056	Wall Mounting Bracket, Telephone

XX = COLOR (See parts catalog for details)

**PUBLICATION INDEX**

A-Lead Control.....4, 21  
 AC Power.....23  
 Access Denied (Private Lines).....2, 63  
 Add-On Conference (Internal).....3, 38  
 All-Call And Zone Paging.....3, 43, 64  
 Answer A Call (Outside Line).....34  
 Answering A Call (Speakerphone Operation).....46  
 Answering A Tone Signalled Intercom Call.....35  
 Answering A Voice Signalled Intercom Call.....36  
 Area Paging Interface.....3, 43  
 Auto Dial Operation.....41  
 Automatic Abandoned Hold Release.....3  
 Automatic Redial (Of Busy Numbers).....4, 39  
 Automatic Hold Transfer To Intercom (Answer Hold).....3  
 Automatic Privacy (Programmable).....4, 38, 63  
 Automatic Abandoned Hold Release.....3, 34  
 Auxiliary Line Port (Direct Access Paging Port).....28  
 Auxiliary Equipment Interface (A-Lead Control).....4, 21  
 Auxiliary Station Ringer Interface.....4  
 BLF Status.....47  
 Base Level Program Entry.....53  
 Basic Key Service (1A2).....4  
 Battery Backup.....5  
 Busy Lamp Field Station (Option).....5, 28, 47  
 Cable Routing.....20  
 Call Announce With Handsfree Answerback.....5  
 Call Origination Denied.....63  
 Call Transfer.....5, 36  
 Checkout.....29  
 Class Of Service Printout.....6, 50  
 Class Of Service And Speed/Auto Dialing Confirmation Tones....49  
 Class Of Service Programming (From Main Station).....6  
 Common Audible and Auxiliary Station Interface.....5  
 Common Line Pickup.....36  
 Configuration.....1  
 Connections.....21  
 DSS/BLF Console (Option).....6, 29, 61, 72  
 Data Line Pairing.....73  
 Data Speed Baud Rate.....59  
 Default Functional Program.....6, 29, 55, 74  
 Delayed Ring Selection.....63  
 Detailed Station Operating Instructions.....33  
 Dial Access Public Address (PA) Port.....27  
 Dial Tone Recall.....7, 43, 57

continued

## Index - continued

Dialing 0 For Attendant.....	6, 46
Direct Ring Selection.....	63
Direct Station Select (DSS) Intercom.....	44
Distinctive Ringing.....	6, 48
Do Not Disturb.....	6, 45
Dual Volume Controls.....	7
End To End Signalling (Off-Hook Dialing).....	7
Exclusive Hold.....	7, 34
External Signalling.....	23
FCC Rules And Regulations.....	16
Failure Analysis Flow Chart.....	75
Failure Analysis.....	73
Failure Isolation.....	72
Features Operation.....	38
Fixed Direct Station Select (DSS).....	7, 43
Flash Operation/Dial Tone Recall.....	7, 43, 57
Flexible Ringing Assignments.....	8
Fuse Location.....	71
General Description.....	1
General Information.....	1
General Information, Programming.....	53
Handset To Speakerphone.....	46
Hearing Aid Compatible Handset.....	8
Hold A Call (Outside Line).....	34
Hold Recall Time Interval.....	57
I Hold and I Use Indications.....	8
Installation.....	19
Installation Requirements.....	16
Intercom Call Progress Tones.....	8, 48
Intercom Calling.....	35
Intercom Line Timeout.....	8
Intercom Signalling, Programming.....	55
Introduction.....	1
KSU Description.....	2
KSU Mounting.....	19
Key System Features.....	2
Last Number Redial.....	8, 38
Line Appearance To Key Assignment.....	64
Line COS Programming.....	59, 67
Line Connections.....	21
Line Preselection (Prime Line).....	8, 45
Maintenance.....	71
Manual Hold.....	9, 34
Manual Scope.....	1

continued

## Index - continued

Memory Dialing Features.....	9
Mixed Station Capacities.....	10
Model 616 System Interconnection.....	26
Model 616 External Signalling.....	24
Model 616B System Interconnection.....	25
Model 616B External Signalling.....	24
Model Variations.....	2
Modular Wiring and Jacks/4-Conductor Wire System.....	10
Momentary Keys with LED Indicators.....	10
Mounting Considerations.....	19
Multiline Conferencing.....	10, 36
Music On Hold.....	10, 28
Mute.....	10, 45
Network Compatibility.....	16
Night Ringing.....	11, 45, 63
Non-Square System/Tenant Service.....	11
Notification To Telephone Company.....	16
On-Hook Dialing/Call Monitor.....	11, 42
Originate A Call (Outside Line).....	34, 46
Originate A Call (Intercom).....	35
Originate A Call (Speakerphone).....	46
Originating Denied.....	11
Operating Conditions, Station.....	48
Optional Features Operation.....	46
Overload Pairing.....	73
PA Connections.....	27, 61
PBX/Centrex/Central Office Compatible.....	11
Paired Stations.....	73
Party Lines And Coin Lines.....	17
Power Failure Transfer.....	11
Power On Visual Indication.....	11
Prime Line.....	12, 61
Printer Connection.....	22
Privacy Release.....	12
Privacy Status.....	59
Programmable Keys.....	12
Programmed Direct Station Select (DSS).....	12, 44
Pull Out Directory.....	12
Pulse Dial Operating Characteristics.....	56
Pulse/Tone Switchable.....	12, 45, 54
Radio Frequency Interference.....	17
Related Information.....	1
Repair Authorization.....	17
Repair Service.....	71
Replacement Parts.....	76
Ringer Equivalence Number.....	18

continued



## Index - continued

Ringling Line Preference.....	12, 46, 62
Saved Number Redial.....	12, 13, 39
Self Test, DSS/BLF Console.....	72
Self Test, Station.....	72
Speakerphone To Handset.....	47
Speakerphone (Option).....	13
Speakerphone Operation.....	46
Specifications.....	14, 15
Speed Dial.....	13, 41, 42
Station COS Programming.....	61, 68
Station Connections.....	21
Station Operating Conditions.....	48
Station Pairing.....	73
Station Self Test.....	72
Storing An Auto Dial Or Speed Dial Number.....	40
Switching Operation Between Handset And Speakerphone.....	46
System COS Programming.....	54, 66
System Default.....	6, 29, 54, 74
System Grounding.....	23
System Operation.....	33
System Programming.....	53
System Status Indicator.....	72
System Transfer.....	36
Technical Assistance.....	71
Telephone Set Mounting.....	20
Telephone Set Description.....	2
Time Interval For A Programmed Pause.....	56
Timed Hold Recall.....	13, 34
Toll Restriction - Expanded.....	13
Toll Restriction - 0 and 1.....	13
Toll Restriction, Station.....	62
Toll Restriction, Line.....	60
Toll Restriction Table Entries.....	58, 69
Tone or Voice Signalling (Intercom).....	14
Troubleshooting.....	17, 71
Visual Indications.....	49
Volume Control (Ringer).....	48
Wall Mounting Adapter (Station).....	14
Zone Paging.....	14

**READERS COMMENT FORM**

Cut along Line

Publication No. \_\_\_\_\_ Issue No. \_\_\_\_\_ Addendum \_\_\_\_\_

Title \_\_\_\_\_

**How did you use this publication?**

- Product familiarization
- Training
- Installation
- Maintenance
- Other \_\_\_\_\_

**Please check specific criticism(s), give page number(s), and explain below:**

- Clarification on page(s) \_\_\_\_\_
- Error on page(s) \_\_\_\_\_
- Addition on page(s) \_\_\_\_\_
- Deletion on page(s) \_\_\_\_\_

Comments: \_\_\_\_\_

\_\_\_\_\_  
\_\_\_\_\_  
\_\_\_\_\_  
\_\_\_\_\_  
\_\_\_\_\_  
\_\_\_\_\_  
\_\_\_\_\_  
\_\_\_\_\_  
\_\_\_\_\_  
\_\_\_\_\_  
\_\_\_\_\_  
\_\_\_\_\_  
\_\_\_\_\_  
\_\_\_\_\_  
\_\_\_\_\_  
\_\_\_\_\_  
\_\_\_\_\_  
\_\_\_\_\_  
\_\_\_\_\_  
\_\_\_\_\_  
\_\_\_\_\_  
\_\_\_\_\_

**Thank you for your cooperation. If a reply is required, please check:**

Cut Along Line

Name \_\_\_\_\_ Date \_\_\_\_\_

Your Function \_\_\_\_\_

Company \_\_\_\_\_

Address \_\_\_\_\_

City, State \_\_\_\_\_ Zip \_\_\_\_\_

## LIMITED WARRANTY

Comdial Corporation (Comdial) warrants that under normal operating conditions, this Equipment (except for fuses, lamps, and other consumables) will be free from defects in material and workmanship for a period of twenty-four (24) months from the manufacturing date stamped on the Equipment. Comdial's sole obligation under this warranty or under any other legal obligation with respect to the Equipment is to repair or replace, at its option, the Equipment if it is deemed defective by Comdial during the warranty period free of charge with new or refurbished equipment or parts, at Comdial's option, when the Equipment is returned to Comdial, freight or postage prepaid, during the warranty period. This warranty does not apply if, in the sole judgement of Comdial, the Equipment has been installed or used in combination or in assembly with products not supplied by Comdial and which are not compatible or inferior quality, design or performance, or the Equipment has been otherwise misused, abused, accidentally damaged, or damaged or malfunctions or fails to function as a result of acts of God such as fire, flood, or lightning or other incidence of excessive or insufficient voltage or failure to follow instructions. Repair or alteration of this Equipment other than as specifically authorized by Comdial or its authorized repair agent is prohibited and will void this warranty. This warranty does not cover costs associated with installation, removal, or reinstallation of the Equipment. Comdial does not warrant that the Equipment is compatible with all telephone or switching systems. THIS WARRANTY IS EXCLUSIVE, BEING IN LIEU OF ALL OTHER WARRANTIES, EXPRESS OR IMPLIED, INCLUDING, BUT NOT LIMITED TO, ANY IMPLIED WARRANTY OF MERCHANTABILITY OR FITNESS FOR A PARTICULAR PURPOSE. WITHOUT EXPANDING UPON THE FOREGOING WARRANTY, THE MAXIMUM LIABILITY OF COMDIAL UNDER ANY WARRANTY, STATUTORY, EXPRESS OR IMPLIED, IS LIMITED TO THE PURCHASE PRICE OF THE EQUIPMENT. COMDIAL SHALL HAVE NO RESPONSIBILITY FOR DAMAGE TO PROPERTY OR ANY OTHER LOSS OR INJURY, INCLUDING CONSEQUENTIAL AND/OR INCIDENTAL DAMAGES, RESULTING FROM THE POSSESSION, OPERATION OR USE OF THE EQUIPMENT, ALL SUCH CLAIMS BEING HEREBY EXPRESSLY WAIVED. THE PURCHASER'S EXCLUSIVE WARRANTY AND REMEDY SHALL BE ONLY AS STATED HEREIN.

This warranty gives you specific legal rights and you may also have other rights which may vary from state to state. Some states do not allow limitations on how long an implied warranty lasts or the exclusion or limitation of incidental or consequential damages, so the above limitations may not apply to you.

If the Magnuson-Moss Act should be held to apply to the sale of the Equipment by a court of competent jurisdiction, the implied warranty of fitness for a particular purpose shall extend for one year from the date of manufacture.

No Comdial dealer nor any other person or entity other than Comdial may extend or modify this warranty, and no such modification or extension shall be effective unless it is in writing.

---

This manual has been developed by Comdial Corporation (the "Company") and is intended for the use of its customers and service personnel. The information in this manual is subject to change without notice. While every effort has been made to eliminate errors, the Company disclaims liability for any difficulties arising for the interpretation of the information contained herein.

The information contained herein does not purport to cover all details or variations in equipment nor to provide for every possible contingency to be met in connection with installation, operation, or maintenance. Should further information be desired, or should particular problems arise which are not covered sufficiently for the purchaser's purposes, contact, Comdial, Customer Service Department, P.O. Box 7266, Charlottesville, Virginia 22906.

Copyright 1988 by Comdial Corporation. All rights reserved.

**COMDIAL**

1180 Seminole Trail  
P. O. Box 7266  
Charlottesville, Virginia 22906-7266  
(800) 431-4345  
(in Virginia 800-654-3345)

716603-700.01  
Printed in U.S.A.